

TEST board for RF module CDP series ECB-03 & DCB-03

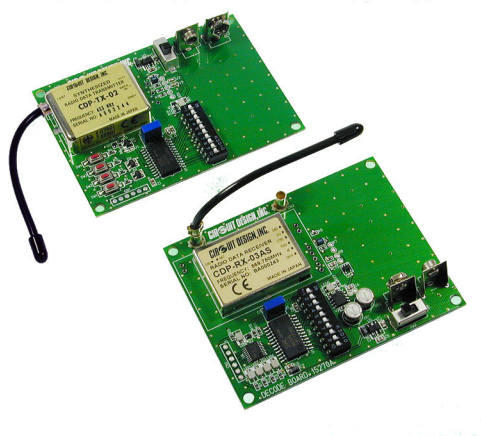

Operation Guide

Version 1.0 (February 2003)

CIRCUIT DESIGN, INC.,

7557-1 Hotaka, Hotaka-machi,
Minamiazumi, Nagano 399-8303 JAPAN
Tel: + +81-(0)263-82-1024
Fax: + +81-(0)263-82-1016

e-mail: cdint@circuitdesign.jp
<http://www.circuitdesign.jp>

CONTENTS

GENERAL DESCRIPTION & FEATURES	2
CDP-TX ENCODE BOARD OPERATION	3
CDP-RX ENCODE BOARD OPERATION	4
DIMENSIONS.....	5
CIRCUIT DIAGRAM	6
CAUTIONS & WARNINGS.....	8

GENERAL DESCRIPTION & FEATURES**General description**

The evaluation board was developed to demonstrate and test the radio data modules CDP-02N and CDP-RX-03AS. This set will save your time and effort for evaluation of CDP radio modules.

It consists of a transmitter encoder board and receiver decoder board.

In combination with the radio modules, it is a full 4 command radio remote control which can be practically used for various applications.

Features

4 inputs & outputs, activated by 4 push buttons.

Encoder & decoder circuit MSM6305 with 1024 user selectable address codes.

4 monitoring LED's on the decoder board

CDP-TX ENCODE BOARD (ECB-03) OPERATION

Batt (+,-) Power terminal

Connect a 9V (006P) battery to the power supply clip. Please be careful with the polarity. Incorrect polarity may result in permanent damage of the boards.

SW 1 - 4 (Operation buttons)

Switches to transmit the each switching signal.

With CDP-TX-02N, the power is always supplied to the module during a main switch is ON. When SW 1- 4 is pushed, the module transmits the switching signal with ID number set at SW5.

SW 5 (10 bits Address switch)

Address switch for equipment. (1024 address can be set). This ID is needed to set same number as ID on decoder board.

SW 6 Main Switch

Main switch for power supply

LED1 Transmission status LED

LED shows the status of transmission. LED turns on while IC which activated by operation button is working.

CN1 Interface terminal

Vcc output terminal and switch terminals.

This terminal enables user to operate the switches from outside. By Applying Vcc level to pin, the encoder board transmit same command as pushing corresponded button.

Pin Number	1	2	3	4	5	6
Description	GND	SW4	SW3	SW2	SW1	Vcc

CDP-RX DECODE BOARD (DCB-03) OPERATION

Batt. (+,-) Power terminal

Connect a 9V (006P) battery to the power supply clip. Please be careful with the polarity. Incorrect polarity may result in permanent damage of the boards.

LED 1 - 4

LED turns on according to operation of the buttons on encode board.

LED 5

LED brightness changes by the received signal strength. RSSI signal out from RX module is used.

LED 6

LED shows the status of decode IC (MSM6305). LED on means that the radio signal is received and IC is working.

SW 1 (10 bits Address switch)

Address switch for equipment. (1024 address can be set). This ID is needed to set same number as ID on encoder board.

SW 2 Main Switch

Main switch for power supply

CN1 Interface terminal

This is output terminal of switches and Vcc/GND. Output terminals are open collector. Following figure is equivalent circuit for the terminal. Suggested operating condition : I = 100mA

Pin Number	1	2	3	4	5	6
Description	GND	SW4	SW3	SW2	SW1	Vcc

Equivalent circuit for output terminal (IN = IC pin)

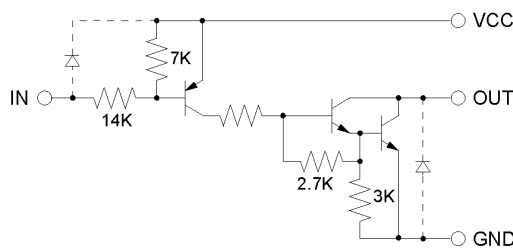

CN2.3 Antenna terminal

Use CN2 for CDP-RX-03AS

Use CN3 for CDP-RX-02N

DIMENSION

ECB-03

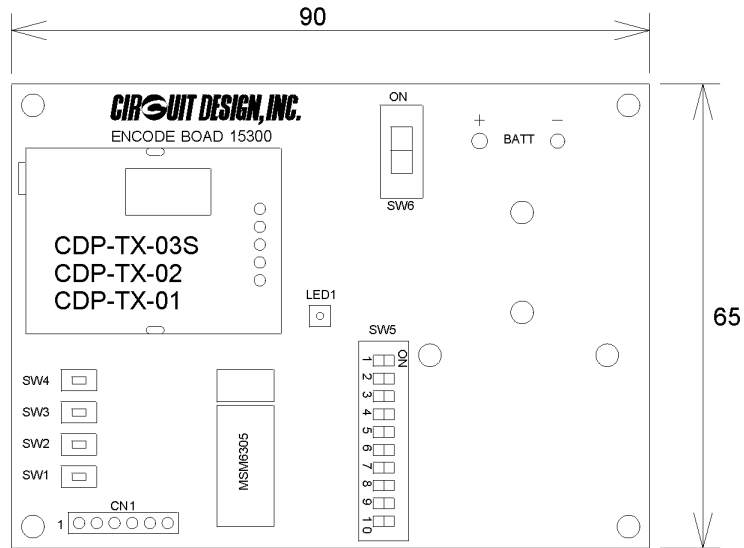

DCB-03

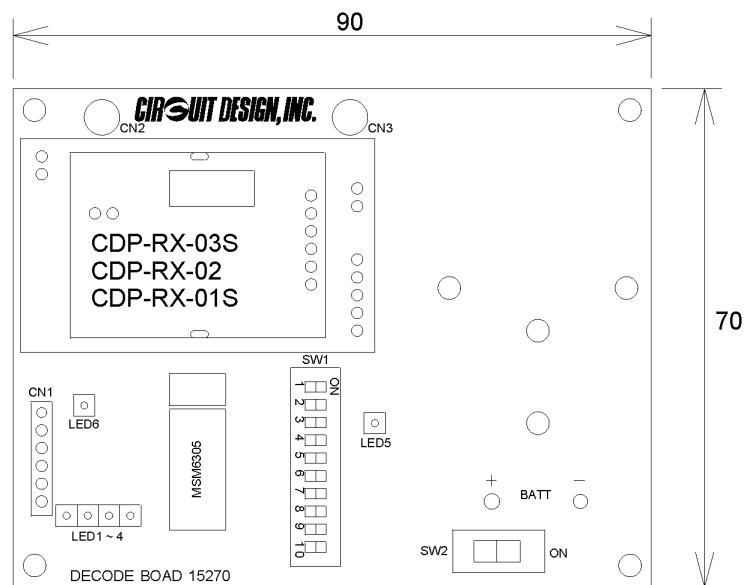

CIRCUIT DIAGRAM (ECB-03)

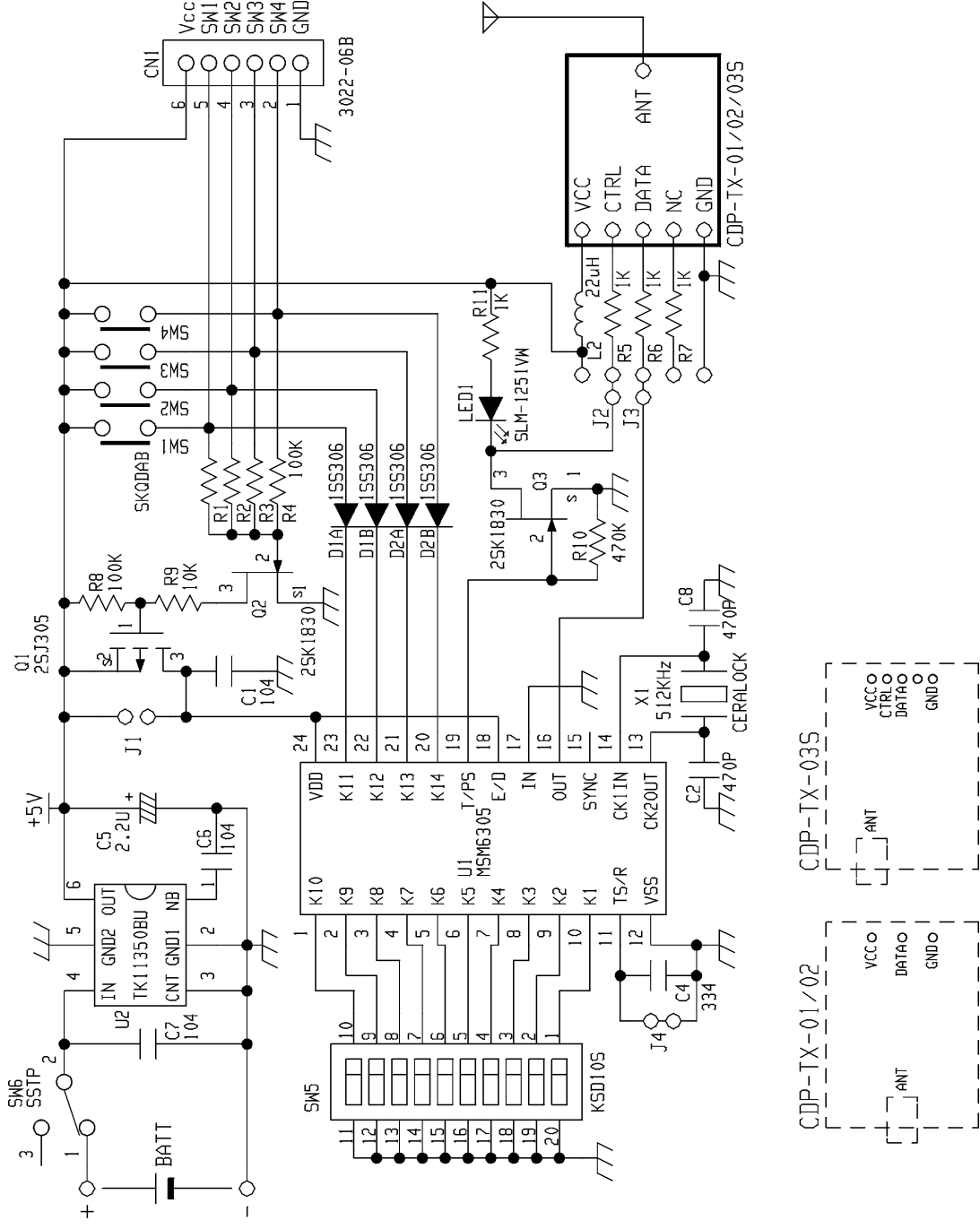

CIRCUIT DIAGRAM (DCB-03)

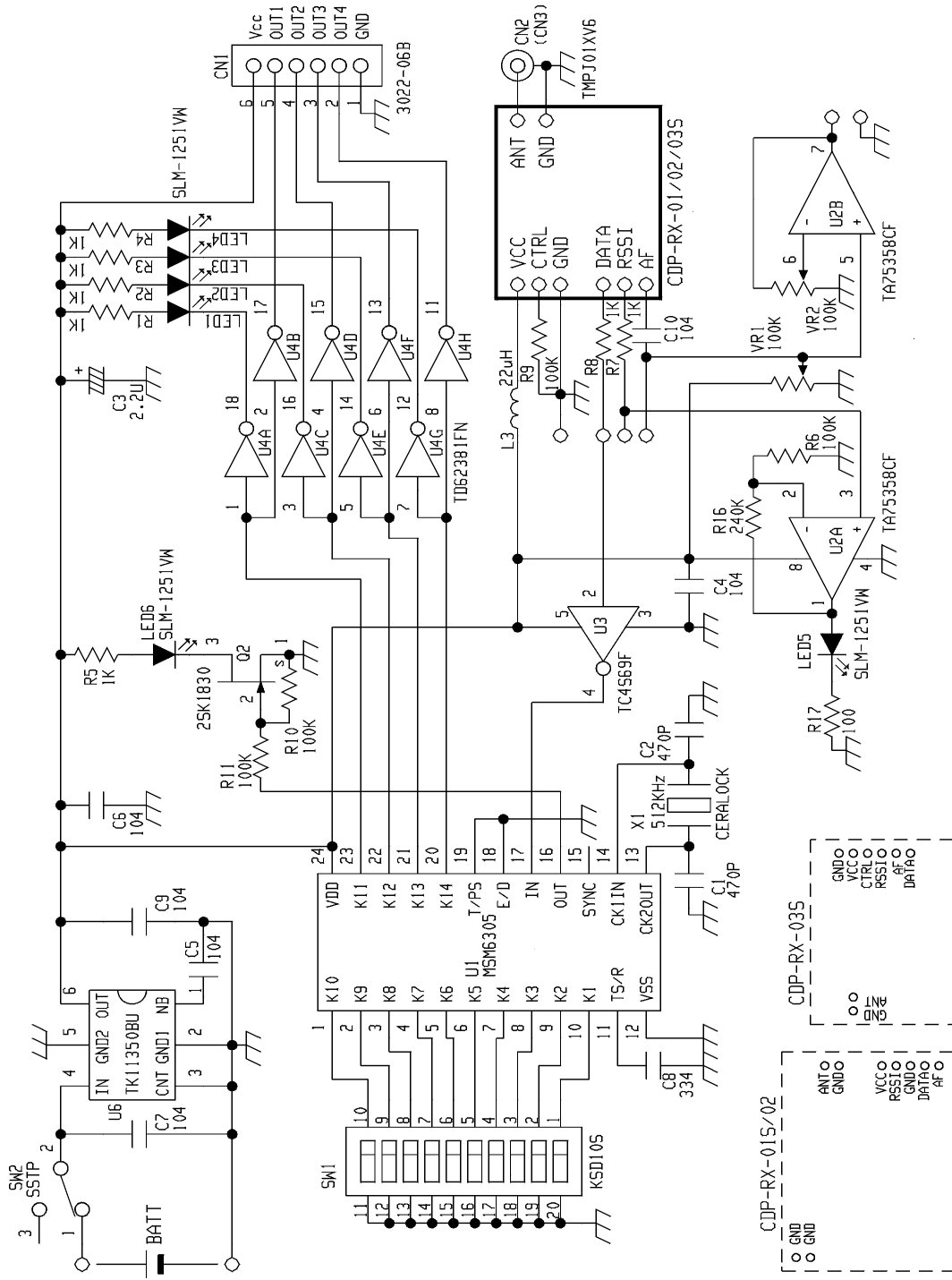

Cautions

- As the product communicates using electronic radio waves, there are cases where transmission will be temporarily cut off due to the surrounding environment and method of usage. The manufacturer is exempt from all responsibility relating to resulting harm to personnel or equipment and other secondary damage.
- Do not use the equipment within the vicinity of devices that may malfunction as a result of electronic radio waves from the product.
- The manufacturer is exempt from all responsibility relating to secondary damage resulting from the operation, performance and reliability of equipment connected to the product.
- Communication performance will be affected by the surrounding environment, so communication tests should be carried out before actual use.
- Ensure that the power supply for the product is within the specified rating. Short circuits and reverse connections may result in overheating and damage and must be avoided at all costs.
- Ensure that the power supply has been switched off before attempting any wiring work.
- The case is connected to the GND terminal of the internal circuit, so do not make contact between the '+' side of the power supply terminal and the case.
- When batteries are used as the power source, avoid short circuits, recharging, dismantling, and pressure. Failure to observe this caution may result in the outbreak of fire, overheating and damage to the equipment. Remove the batteries when the equipment is not to be used for a long period of time. Failure to observe this caution may result in battery leaks and damage to the equipment.
- Do not use this product in vehicles with the windows closed, in locations where it is subject to direct sunlight, or in locations with extremely high humidity.
- The product is neither waterproof nor splash proof. Ensure that it is not splashed with soot or water. Do not use the equipment if water or other foreign matter has entered the case.
- Do not drop the product or otherwise subject it to strong shocks.
- Do not subject the equipment to condensation (including moving it from cold locations to locations with a significant increase in temperature.)
- Do not use the equipment in locations where it is likely to be affected by acid, alkalis, organic agents or corrosive gas.
- The GND for the product will also affect communication performance. If possible, ensure that the case GND and the circuit GND are connected to a large GND pattern.

Warnings

- Do not take apart or modify the equipment.
- Do not remove the product label (the label attached to the upper surface of the product.) Using a product from which the label has been removed is prohibited.

Circuit Design, Inc. All right reserved

No part of this document may be copied or distributed in part or in whole without the prior written consent of Circuit Design, Inc.

Customers are advised to consult with Circuit Design sales representatives before ordering.

Circuit Design, Inc. believes the furnished information is accurate and reliable. However, Circuit Design, Inc. reserves the right to make changes to this product without notice.