

433MHz high speed FM radio transceiver module

The BiM2 transceiver is an enhanced replacement for our original BiM module. It offers greater transmit power, higher data rates, greatly improved receiver interference rejection and a lower profile. The module is ideal for enabling bi-directional wireless connectivity in battery powered or handheld applications



BiM2-433-160

Features

- CE Certified by independent Notified Body according to the R&TTE Directive (1999/5/EC)
- Verified to comply with Radio standard ETSI EN 300 220-3 by UKAS accredited Test Laboratory
- Verified to comply with EMC standard ETSI EN 301 489-3 by UKAS accredited Test Laboratory
- Usable range to 200 metres external, 50 metres in building
- Data rates up to 160kbps
- SAW controlled 10mW FM transmitter
- Double conversion FM superhet receiver
- SAW front end filter and full screening
- Plug in replacement for Radiometrix BiM-433-40
- 3V or 5Volt supply at < 20mA

The BiM2 is a half duplex radio transceiver module for use in high-speed bi-directional data transfer applications at ranges up to 200metres. The module operates on the European licence exempt frequency of 433.92MHz. The small footprint of 23 x 33mm and low profile of 4mm together with low power requirements of <20mA @ 3 to 5 Volts enable convenient PCB installation. The high raw data rate capability of 64kbps and fast state change times will support high data throughput of up to 3 kbyte/s in 'streaming' applications or alternatively allows very short air time utilization in multi-node scanning networks.

Applications

- PDA's, organizers and laptops
- Handheld terminals
- EPOS equipment, barcode scanners, belt clip printers
- Data loggers
- Audience response systems
- In Building environmental monitoring and control
- High end security and fire alarms
- Restaurant ordering systems
- Vehicle data up/download

Further information will be available imminently, however, BiM-433-F data sheets contains applications information that is equally applicable to the new BiM2.

Functional overview

The transmit section of the BiM2 comprises of a SAW stabilised and FM modulated 433.92MHz oscillator feeding a 10mW buffer/output stage. Operation is controlled by a TX select line, the output achieving full power within 100µs of this line being pulled low. Modulation is applied at the TXD input and may be either a serial digital stream at the same levels as the module's supply rails (digital drive) or a high level analogue waveform with a pk to pk amplitude close to the modules supply level (linear drive). Modulation shaping is performed internally by a 2nd order 44kHz LPF to minimize spectral spreading. The RF output is filtered to meet the requirements of EN 300-220-3 and fed via a fast antenna changeover switch to the 50Ω antenna pin.

The receive section of the BiM2 is a double conversion FM superhet with IF's of 16MHz and 150kHz. The dual gate MOSFET LNA is followed by a 750kHz bandwidth SAW filter to provide >60 dB's rejection of all out of band signals. The receiver is controlled by an active low select line and will power up in <1ms. A post-detection 2nd order 35kHz LPF establishes the signal bandwidth and ensures the clean operation of the subsequent adaptive data slicer. The slicer has a 2ms averaging time constant and is optimised for balanced data, e.g. bi-phase codes. A fast acting carrier detect output will indicate the presence of any RF signals.

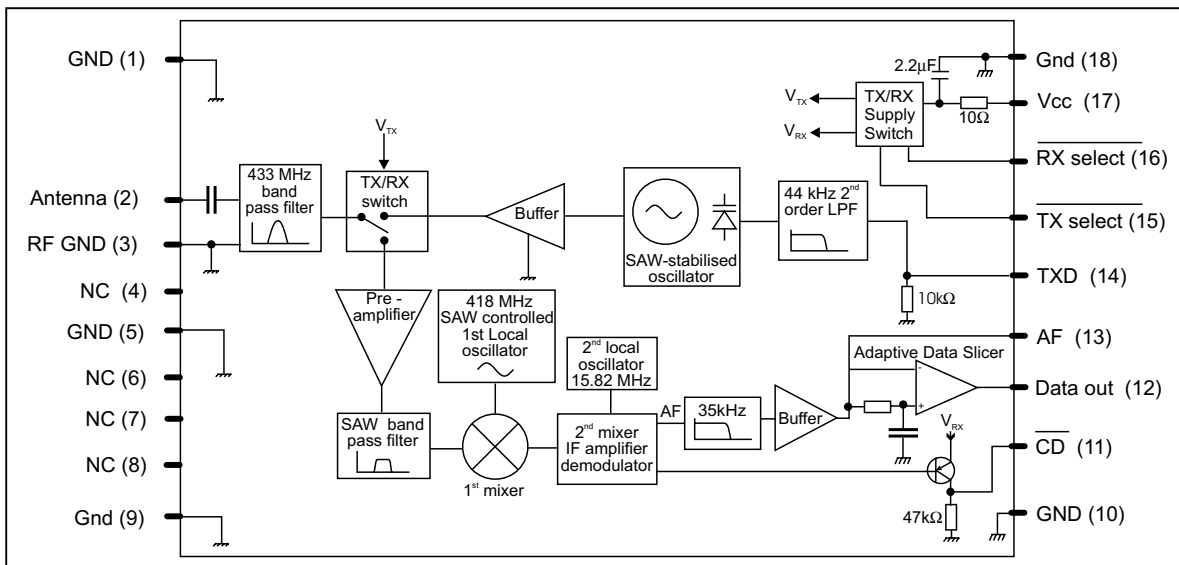

Figure 1: Block diagram

Pin description:

RF GND *pin 1 & 3*

RF ground pin, internally connected to the module screen and pin 5, 9, 10, 18 (0 Volt). This pin should be connected to the RF return path (e.g. coax braid, main PCB ground plane etc.)

Antenna *pin 2*

50Ω RF input from the antenna, it is DC isolated internally. (see antenna for suggested antenna/feeds).

0Volt *pins 5, 9, 10, 18*

Supply ground connection and screen.

CD *pin 11*

Carrier Detect - When the receiver is enabled, a low indicates a signal above the detection threshold is being received. The output is high impedance (50kΩ) and should only be used to drive a CMOS logic input.

RXD *pin 12*

This digital output from the internal data slicer is a squared version of the signal on pin 13 (AF). It may be used to drive external decoders. The data is true data, i.e. as fed to the transmitter. Load impedance should be >1kΩ and <1nF

AF *pin 13*

This is a buffered and filtered analogue output from the FM demodulator. It has a standing DC bias of 1.2 volts and 400mV_{P-P} base band signal. It is useful as a test point or to drive linear decoders. Load impedance should be >2kΩ and <100pF.

TXD *pin 14*

This DC coupled modulation input will accept either serial digital data (0V to Vcc levels) or High level linear signals. Input impedance is 10kΩ.

TX select *pin 15*

Active low transmit select. 10kΩ internal pull up to Vcc.

RX select *pin 16*

Active low receive select. 10kΩ internal pull up to Vcc.

Pin 15 TX	Pin 16 RX	Function
1	1	power down (<1μA)
1	0	receiver enabled
0	1	transmitter enabled
0	0	self test loop back

Note: Loop test allows the receivers to monitor the transmitted signal. The receiver will not receive external signals whilst the TX of the module is enabled.

Vcc *pin 17*

+ve supply pin. +3.0 to +5.5 volts @ <20mA . The supply must be clean < 20mV_{P-P} ripple. A 2.2μF decoupling capacitor and 10Ω series resistor are used internally to filter the supply.

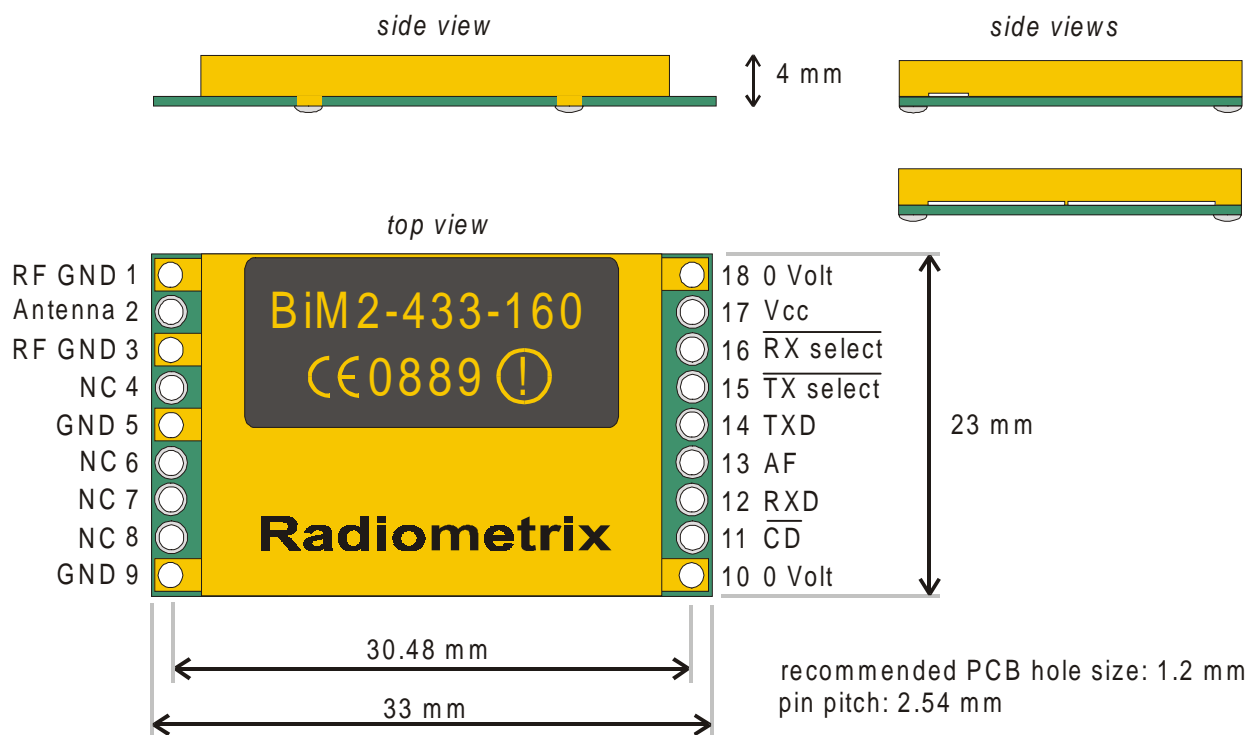

Figure 2: Physical dimension

Weight: 5g (typical with pins)

Survival Maximums:

Operating temperature: -10°C to + 55°C
 Extended operation at -20°C to + 70°C
 Reduced specification
 Storage temperature : -40°C to + 100°C

Vcc (pin 17) -0.1V to +10.0 V
 All other pins -0.1V to +Vcc+0.6V
 Antenna (pin 2) ±50 V @ <10MHz , +20dBm @ > 10MHz

Note: Operation of the BiM2 above 5.5 volt with efficient antenna may result in radiated power levels above the licensed power level.

Figures apply to 5V versions unless otherwise noted

Temperature 20° C unless noted

Electrical Performance	pin	min.	typ.	max.	units	notes
DC Levels						
supply voltage, Vcc (std. version)	17	4.0	5	5.5	V	
supply voltage, Vcc (3V version)	17	3.0	3.3	4.0	V	
TX supply current, Vcc (std)	17	10	14	16	mA	
TX supply current, Vcc (3.3V)	17	6	8	10	mA	3.3V supply
RX supply current, Vcc (std)	17	12	18	21	mA	
RX supply current, Vcc (3.3V)	17	10	14	17	mA	3.3V supply
supply ripple allowed	17	-	-	20	mV _{pk-pk}	below 1MHz
AF output DC level	13	1.0	1.25	1.5	V	
load capacitance on AF / Data	12,13	-	-	100	pF	
CD output load resistance	11	220	-	-	kΩ	Note 2
Interface levels						
data output high, 100µA source	12	-	Vcc-0.6	-	V	RXD high
data output low, 100µA sink	12	-	0.4	-	V	RXD low
TX & RX select, high (deselect)						
low (select)	15, 16	0		0.5	V	
Internal select pull-ups	15,16	-	10	-	kΩ	
TXD, high	14	Vcc-0.5		Vcc	V	
low	14	0		0.5	V	

RF Parameters	pin	min.	typ.	max.	units	notes
Antenna pin impedance	2	-	50	-	Ω	TX or RX
RF centre frequency	-	-	433.92	-	MHz	
Transmitter						
RF power output, Vcc std	2	+7	+10	+12	dBm	5V
RF power output, Vcc 3.3V	2	+3	+6	+8	dBm	3.3V
Initial frequency accuracy	-	-50	0	+50	kHz	
Overall frequency accuracy	-	-100	0	+100	kHz	
FM deviation	-	20	30	40	kHz	
Modulation bandwidth	-	DC	-	32	kHz	
Modulation bandwidth	-	DC	-	80	kHz	160kbps
Modulation distortion	-	-	-	15	%	
Receiver						
RF sensitivity, 10dB S/N	2, 13	-95	-101		dBm	
RF sensitivity, 10dB S/N	2, 13	-91	-96		dBm	3.3V
RF sensitivity, 10dB S/N	2, 13		-94		dBm	160kbps

RF Parameters	pin	min.	typ.	max.	units	notes
RF sensitivity, 1ppm BER	2, 12	-87	-93		dBm	5V
RF sensitivity, 1ppm BER	2, 12	-82	-88		dBm	3.3V
RF sensitivity, 1ppm BER	2, 12		-90		dBm	160kbps
CD threshold, Vcc = 5V	2, 11	-98	-104		dBm	Note 2
CD threshold, Vcc = 3V	2, 11	-92	-98		dBm	Note 2
CD threshold, Vcc = 5V	2, 11		-96		dBm	Note 2
IF bandwidth, Vcc = 5V, 160kbps	-	-	500	-	kHz	
CD bandwidth	2, 11	-	400	-	kHz	Note 2
Ultimate (S+N)/N, -70dBm input	13	-	>40	-	dB	
Ultimate (S+N)/N, -70dBm input	13		30		dB	160kbps
maximum operating RF input	2	-	+10	-	dBm	
AF output level	13	-	400	-	mV	peak to peak
Initial frequency accuracy	-	-50	0	+50	kHz	CD centre

EMC Parameters	pin	min.	typ.	max.	units	notes
Rejections: rejection figures are relative to a 15dB (S+N)/N wanted signal						
Co-channel rejection	2	-	-10	-	dB	
Image rejection ($f_{RF}-2f_{IF}$)	2	-	64	-	dB	402.0MHz
Out of band rejection	2	-	>70	-	dB	DC to 2GHz
AM rejection	2	-	>30	-	dB	
Out of band blocking level	2	-	>-15	-	dBm	
Out of band IP ₃	2	-	+1	-	dBm	
Radiations						
RX LO leakage, conducted	2	-	-60	-57	dBm	
RX LO leakage, radiated	-	-	-70	-	dBm	
TX 2 nd harmonic	2	-	-42	-36	dBm	
TX harmonics >1GHz	2	-	-40	-30	dBm	
TX spectral bandwidth @-40dBc	2	-	-	250	kHz	worst case

Baseband Transfer Performance	pin	min.	typ.	max.	units	notes
TX→RX						
Linear baseband BW @-3dB	13	0.08	-	34	kHz	TXD to AF
Linear baseband BW @-3dB,	13	0.08	-	80	kHz	160kbps
Balance code bit rate	12	-	64	-	kbps	
Time between code transitions	14	15.6	-	1000	μs	
Time between code transitions	14	15.6	-	120	μs	S version
Time between code transitions	14	6.25	-	100	μs	160kbps
Averaged code mark:space	14	30	50	70	%	in any 2ms
preamble duration	14	3	-	-	ms	01010101 pattern
preamble duration	14	1	-	-	ms	S version
link delay	14, 12	-	15	-	μs	TXD to RXD
Dynamic Timing						
<i>Power up with signal present</i>						
Power up to valid CD, t _{PU-CD}	11	-	0.7	1	ms	Note 2
Power up to stable AF, t _{PU-AF}	13	-	0.5	1	ms	
Power up to stable data, t _{PU-data}	12	-	3	5	ms	
Power up to stable data, t _{PU-data}	12	-	-	1	ms	1, S version
Power up to stable data, t _{PU-data}	12	-	-	0.8	ms	160kbps

Baseband Transfer Performance	pin	min.	typ.	max.	units	notes
<i>Signal applied with supply on</i>						
Signal to valid CD, t_{sig-CD}	11	-	0.25	0.5	ms	Note 2
Signal to stable data, $t_{sig-data}$	12	-	3	4	ms	
Signal to stable data, $t_{sig-data}$	12	-	-	1	ms	1, S version
Signal to stable data, $t_{sig-data}$	12	-	-	0.5	ms	
TX power up to full RF	2	-	100	-	μ s	

Notes: 1. from 45% to 55% duty cycle
2. CD works up to 40° C

Antenna requirements

Three types of integral antenna are recommended and approved for use with the module:

- A) **Helical** Wire coil, connected directly to pin 2, open circuit at other end. This antenna is very efficient given it's small size (20mm x 4mm dia.). The helical is a high Q antenna, trim the wire length or expand the coil for optimum results. The helical de-tunes badly with proximity to other conductive objects.
- B) **Loop** A loop of PCB track tuned by a fixed or variable capacitor to ground at the 'hot' end and fed from pin 2 at a point 20% from the ground end. Loops have high immunity to proximity de-tuning.
- C) **Whip** This is a wire, rod ,PCB track or combination connected directly to pin 2 of the module. Optimum total length is 16cm (1/4 wave @ 433MHz). Keep the open circuit (hot) end well away from metal components to prevent serious de-tuning. Whips are ground plane sensitive and will benefit from internal 1/4 wave earthed radial(s) if the product is small and plastic cased

	A	B	C
	<i>helical</i>	<i>loop</i>	<i>whip</i>
Ultimate performance	**	*	***
Easy of design set-up	**	*	***
Size	***	**	*
Immunity proximity effects	**	***	*
Range open ground to similar antenna			200m

The antenna choice and position directly controls the system range. Keep it clear of other metal in the system, particularly the 'hot' end. The best position by far, is sticking out the top of the product. This is often not desirable for practical/ergonomic reasons thus a compromise may need to be reached. If an internal antenna must be used, try to keep it away from other metal components, particularly large ones like transformers, batteries and PCB tracks/earth plane. The space around the antenna is as important as the antenna itself.

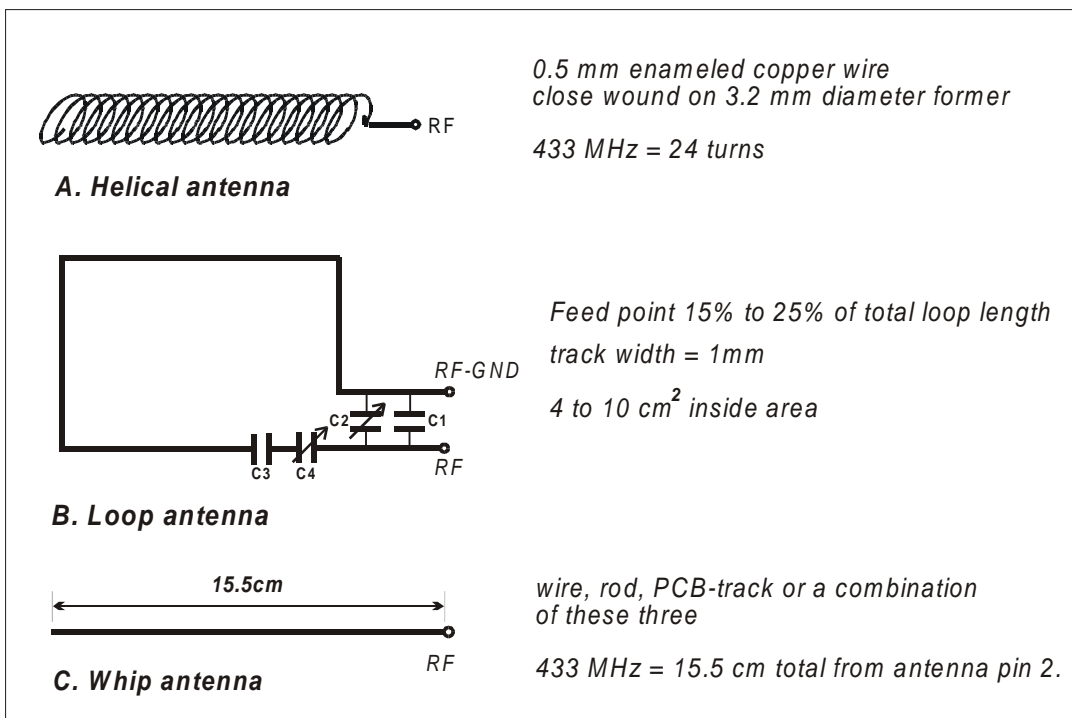

Figure 3: Antenna

Ordering information

The standard BiM2, order code BiM2-433-64 is supplied with pins fitted for operation on 5 volt supplies (4 to 5.5v)

Versions and Variants

BiM2-433-64-3V

A 3 volt version is available, BiM-433-64-3V for operation at 3.3volts (3.0 to 4.0 V) it is identical to the standard version but has been tested and aligned for operation at 3.3v.

BiM2-433-64-S

This is intended for RPC or Manchester code only and has fast settling time (maximum 1ms)

Additionally, for volume orders, Radiometrix can supply the BiM2 to the customers' PCB pin requirements or even without any pins.

BiM2-433-160-5V

This fast version BiM2 has a raw data rate of up to 160kbps. 3V version also available (BiM2-433-160-3V).



Radio Frequency Investigation Ltd

Earlscourt Park, Ramsdell, Basingstoke,
Hampshire RG26 5RD

Switchboard Tel: +44 (0) 1256 851183

Sales Tel: +44 (0) 1256 855400

Fax: +44 (0) 1256 851192

E-mail: sales@rfi-wireless.com

Web Site: www.rfi-wireless.com

CERTIFICATE OF CONFORMANCE FROM RADIO FREQUENCY INVESTIGATION LTD.

Test Of: Radiometrix Ltd
BIM2-433 Transceiver

To: EN 300 220-1 V1.3.1 (2000-09)
according to the requirements of EN 300 220-3 V1.1.1 (2000-09),
Harmonised EN covering essential requirements
under Article 3.2 of the R&TTE Directive

Certificate of Conformance Serial No:
RFI/MPTB1/SC42137F

<p>This is to certify that a sample of the equipment defined above has been tested by Radio Frequency Investigation Ltd. (Basingstoke) to the above standard as detailed in RFI report number RFI/MPTB1/RP42137F. In the configuration tested the equipment was compliant with the standard or parts of the standard applied to the sample.</p> <p>For full details please refer to document RFI/MPTB1/RP42137F</p>	
<p>Tested By: <i>N. J. Cole</i></p>	<p>Approved Signatory: <i>N. J. Cole</i></p>
<p>Certificate Copy No: 01</p>	<p>Test Item Receipt Date: 27 June 2001</p>
<p>Issue Date: 17 October 2001</p>	<p>Test Date: 02 August 2001 to 10 September 2001</p>
<p>Issued to: Mr G. Sharples Managing Director Radiometrix Ltd Hartcran House Gibbs Couch Carpenders Park Watford Hertfordshire WD1 5EZ</p>	<p>Deviations from tested standard: None.</p>
<p>This certificate may be reproduced in full. Partial reproduction may only be made with the written consent of Radio Frequency Investigation Ltd. This certificate applies only to the sample(s) tested.</p>	

A CATALYST IN WIRELESS DEVELOPMENT

Registered in England, No. 211 7001 Registered Office: Earlscourt Park, Ramsdell, Basingstoke, Hampshire RG26 5RD





Radio Frequency Investigation Ltd

Exhurst Park, Ramsted, Basingstoke,
Hampshire RG26 5RQ

Switchboard Tel: +44 (0) 1256 851193

Sales Tel: +44 (0) 1256 855400

Fax: +44 (0) 1256 851192

E-mail: sales@rfi-wireless.com

Web Site: www.rfi-wireless.com

CERTIFICATE OF CONFORMANCE FROM RADIO FREQUENCY INVESTIGATION LTD.

Test Of: Radiometrix Ltd.
BIM2-433

To: EN 301 489-1 V1.2.1 (2000-08)
according to the specific conditions
detailed in EN 301 489-3 V1.2.1 (2000-08)
(requested parts only)

Certificate of Conformance Serial No:
RFIEMCB1/TC42137ETF13A

This is to certify that a sample of the equipment defined above has been tested by Radio Frequency Investigation Ltd. (Basingstoke) to the above standard as detailed in RFI report number RFIEMCB1/TS42137ETF13A. In the configuration tested the equipment was compliant with the standard or parts of the standard applied to the sample.

For full details please refer to document RFIEMCB1/TS42137ETF13A

Tested By:

Approved Signatory:

Certificate Copy No:

Test Item Receipt Date: 11 June 2001

Issue Date: 25 July 2001

Test Date: 29 June 2001

Issued to:
Radiometrix Ltd
Harteran House
Gibbs Couch
Carpenders Park
Watford
WD1 5EZ
Hertfordshire

Deviations from tested standard:
None.

This certificate may be reproduced in full. Partial reproduction may only be made with the written consent of Radio Frequency Investigation Ltd.
This certificate applies only to the sample(s) tested.

A CATALYST IN WIRELESS DEVELOPMENT

Registered in England, No. 271 757. Registered Office: Exhurst Park, Ramsted, Basingstoke, Hampshire RG26 5RQ



CE Certificate for BiM2-433-64 and its variants



Radio Frequency Investigation Ltd

NOTIFIED BODY OPINION RFI/NBCB1/42627JD03

Applicants Details

Applicant's Company Name: Radiometrix Ltd
Address: Hartcran House, Gibbs Couch, Carpenters Park, Watford, Herts.,
WD1 5EZ
Contact Name: Mr S. Paramanathan

Manufacturers Details

Manufacturer's Company Name: Radiometrix Ltd
Address: Hartcran House, Gibbs Couch, Carpenters Park, Watford, Herts.,
WD1 5EZ
Contact Name: Mr S. Paramanathan

Product Details

Product Name: BiM2-433
Model Number(s): BiM2-433-64-5V
BiM2-433-64-3V
BiM2-433-64-S
TCF Reference Number: RM/BIM2/DTD
Standard(s): EN 300 220-1 V1.3.1 (2000-09) according to the requirements of EN
300 220-3 V1.1.1 (2000-09)
Description: FM Radio Transceiver Module

In the opinion of RFI, the Technical Construction File demonstrates that the Apparatus to which it relates conforms to the essential requirements of Article 3.2 of Council Directive 1999/5/EC on radio equipment and telecommunications terminal equipment and the mutual recognition of their conformity. The Apparatus cannot be used with a loop antenna.

Authorised Signatory:

A handwritten signature in black ink, appearing to read 'N Cobb', is written over a horizontal line.

Mr N Cobb

16-10-01

Date



Notified Body Number 0889

Company Seal

Radio Frequency Investigation Ltd, Carpenters Park, Ramsdell, Basingstoke, Hampshire RG26 5RQ, ENGLAND
Tel: +44 (0) 1256 851193 Fax: +44 (0) 1256 851192 E-mail: sales@rfi.co.uk
Registered in England, No. 211 7901

Radiometrix Ltd

Hartcran House

Gibbs Couch

Watford

WD19 5EZ

ENGLAND

Tel: +44 (0)20 8428 1220

Fax: +44 (0)20 8428 1221

info@radiometrix.co.uk

www.radiometrix.co.uk

Copyright notice

This product data sheet is the original work and copyrighted property of Radiometrix Ltd. Reproduction in whole or in part must give clear acknowledgement to the copyright owner.

Limitation of liability

The information furnished by Radiometrix Ltd is believed to be accurate and reliable. Radiometrix Ltd reserves the right to make changes or improvements in the design, specification or manufacture of its subassembly products without notice. Radiometrix Ltd does not assume any liability arising from the application or use of any product or circuit described herein, nor for any infringements of patents or other rights of third parties which may result from the use of its products. This data sheet neither states nor implies warranty of any kind, including fitness for any particular application. These radio devices may be subject to radio interference and may not function as intended if interference is present. We do NOT recommend their use for life critical applications.

The Intrastat commodity code for all our modules is: 8542 6000.

R&TTE Directive

After 7 April 2001 the manufacturer can only place finished product on the market under the provisions of the R&TTE Directive. Equipment within the scope of the R&TTE Directive may demonstrate compliance to the essential requirements specified in Article 3 of the Directive, as appropriate to the particular equipment.

Further details are available on Radiocommunications Agency (RA) web site:

<http://www.radio.gov.uk/topics/conformity/conform-index.htm>

The Library and Information Service

The Radiocommunications Agency

Wyndham House

189 Marsh Wall

London E14 9SX

United Kingdom

Tel: +44 (0)20 7211 0502/0505

Fax: +44 (0)20 7211 0507

library@ra.gsi.gov.uk

For further information on radio matters

contact the Agency's 24 Hour Telephone

Enquiry Point. +44 (0)20 7211 0211

European Radiocommunications Office (ERO)

Midtermolen 1

DK 2100 Copenhagen

Denmark

Tel. +45 35250300

Fax +45 35250330

ero@ero.dk

www.ero.dk