

# Radiometrix

Hartcran House, Gibbs Couch, Watford, WD19 5EZ, England

Tel: +44 (0) 20 8428 1220. Fax: +44 (0) 20 8428 1221

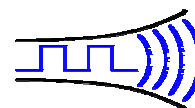

Control44

Issue: 4, June 2004

## 4 bit Address - 4 bit Data encoder/decoder

**Control44 is a 4 bit address, 4 bit data encoder and decoder combined in a single IC. This device can operate in either Encode or Decode mode. It uses 1kbps differential Manchester bit balancing with preamble and checksum. CTR44 is specifically designed to be used in RF remote control applications. It is available in 20pin SSOP, 18pin SOIC and PDIP packages.**



Figure 1: Control44 in SO, DIL packages

## Features

- Operating voltage (temperature):
  - 3.0V-5.5V for standard version (-40°C to +125°C)
  - 2.0V-5.5V for low voltage version (-40°C to +85°C)
- Draws <2mA without external load
- 4 bit address and 4 bit data
- 16 different remotes with 4 controls each
- Single packetised transmission for fast activation
- Maximum usage of the range capability of an RF module
- Adequate preamble to settle data slicer in the receiver.
- Extra wake up preamble to allow for transmitter power up time requirements
- Differential Manchester encoding of address, data and checksum
- Synchronisation codes and checksum to reduce false triggering on noise
- Suitable to be used with Narrow Band FM radio modules
- Ceramic resonator or crystal oscillator up to 20MHz
- Data rate up to 5.6kbps
- Minimum external component requirement
- 4 wire, push button and latched push button modes
- Custom address, data bit variations available subject to minimum order quantity

## Applications

- Security and Alarm systems
- Emergency assistance call system
- Status reporting and monitoring systems
- RF Remote control systems
- Industrial controls
- HVAC controls
- Simple On/Off switching
- Long range telecontrol with Narrow Band FM radios

## Encoder Mode

Control44 can be put into Encoder Mode by connecting Mode (pin 2) to supply.

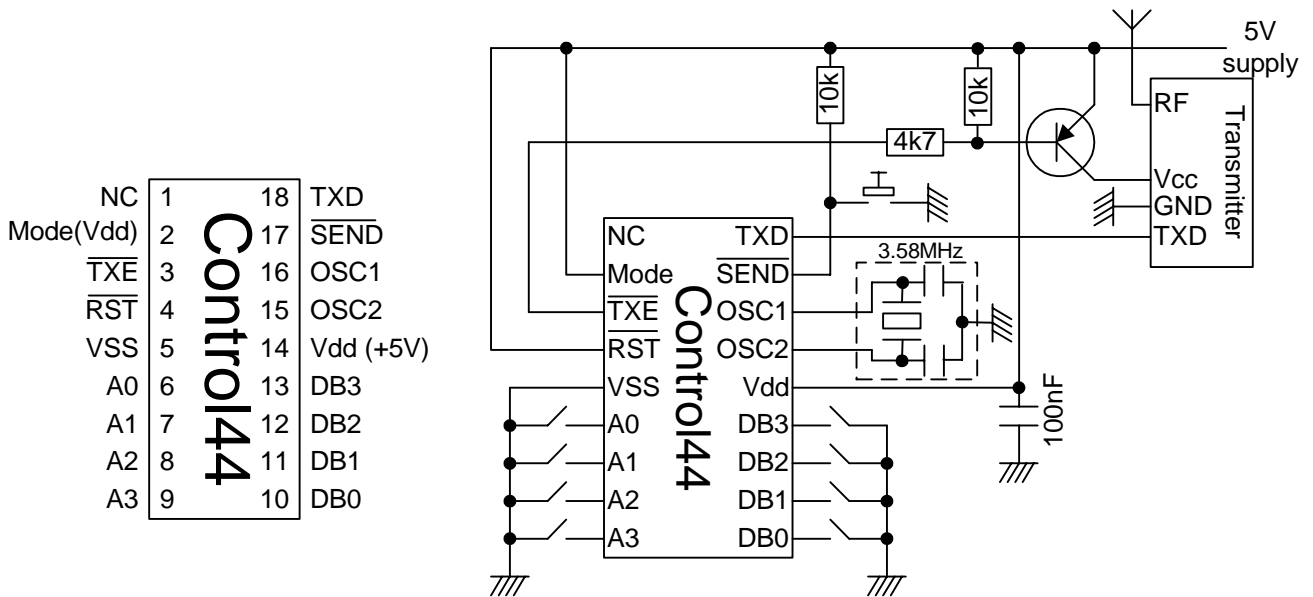

Figure 2: Control44 in Encoder Mode

Pin	Name	Input/Output	Description
1	NC		
2	Mode	Input	RX=0V, TX=Vdd (no pull-up, only read at reset/power up)
3	$\overline{\text{TXE}}$	Output	Active Low RF Transmitter Enable (Open drain, require 10k pull-up) <sup>4,6</sup>
4	$\overline{\text{RST}}$	Input	Active Low Reset (Connect to user system reset or tie to Vdd)
5	VSS	Supply	Supply Ground
6-9	A3:A0	Input	Least significant 4 bits of Address (Internal pull-ups to Vdd) <sup>1,5</sup>
10-13	DB3:DB0	Input	Least significant 4 bits of Data B (Internal pull-ups to Vdd) <sup>5</sup>
14	Vdd	Supply	4.5-5.5V supply (decouple with 0.1µF close to IC)
15	OSC2	Output	3.58MHz resonator <sup>2</sup>
16	OSC1	Input	3.58MHz resonator <sup>2</sup>
17	$\overline{\text{SEND}}$	Input	Active Low Send Packet (Encoder Enable) <sup>3</sup>
18	TXD	Output	Encoded Address and Data to TXD input of RF Transmitter

## Decoder Mode

Control44 can be put into Decoder Mode by connecting Mode (pin 2) to Ground.

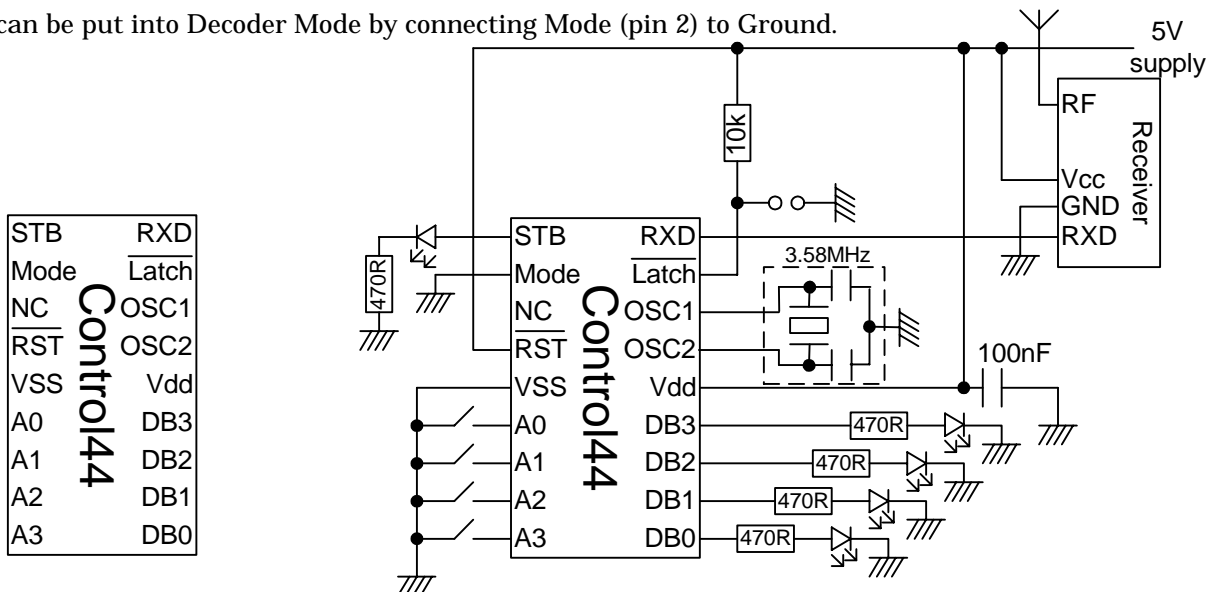

Figure 3: Control44 in Decoder Mode

Pin	Name	Input/Output	Description
1	STB	Output	Positive going pulse on reception of valid data packet. 10 $\mu$ s duration
2	Mode	Input	RX=0V, TX=Vdd (no pull-up, only read at reset/power up)
3	NC		
4	RST	Input	Active Low Reset (Connect to user system reset or tie to Vdd)
5	VSS	Supply	Supply Ground
6-9	A3:A0	Input	Least significant 4 bits of Address (Internal pull-ups to Vdd) <sup>1,5</sup>
10-13	DA3:DA0	Output	Least significant 4 bits of Data A <sup>5</sup>
14	Vdd	Supply	4.5-5.5V supply (decouple with 0.1 $\mu$ F close to IC)
15	OSC2	Output	3.58MHz resonator <sup>2</sup>
16	OSC1	Input	3.58MHz resonator <sup>2</sup>
17	Latch	Input	0V = latch DA3:D0 until next packet Vdd = clear DA3:DA0 after 150ms (no pull-up)
18	RXD	Input	Encoded Address and Data from RXD Output of RF Receiver

**Notes:**

1. Only 4 of the 6 address bits are accessible. A5,A4 are set to 0 in CTR44
2. OSC1,2 require a 3.58MHz ceramic resonator with internal capacitors like Murata CSTLA3M58G55-B0. If a 2 pin resonator or crystal is used, then two 15pF-22pF caps are needed: one from OSC1 to 0V another from OSC2 to 0V. 100 $\Omega$  series resistor between OSC2 and crystal may be required when driving low frequency crystal with High Speed (H) CTR44H version.
3. If a low going pulse of between 10 $\mu$ s and 50ms is applied to SEND pin then a single packet will be transmitted
4. After asserting TXE low (active), the encoder allows 55ms for NBFM TX to power up and settle
5. Absolute maximum source/sink current from each DB3:DB0 pin is 25mA
6. TXE is an open drain output (no pull-up). Connect it to Vdd via a 10k $\Omega$  pull-up resistor
7. MODE pin is only read at reset/power up. Connect to either Vdd (Encoder) or 0V (Decoder).
8. Without external loads the CTR44 draws <2mA from 5V supply.
9. Standard version can be used down to 3V for <10MHz oscillator.  
Low voltage version can be used down to 2V for <4MHz oscillator.
10. High Speed, CTR44H, version should not be used with Narrow Band FM radio modules.

**Encoded Data Packet Format**

Transmission format is 1kbps differential Manchester encoding when using 3.58MHz resonator. Oscillator frequency can be decreased to suit narrow band RF module data rate requirements. CTR44H IC running at 20MHz can be used with wideband radio modules for fast data transmission.

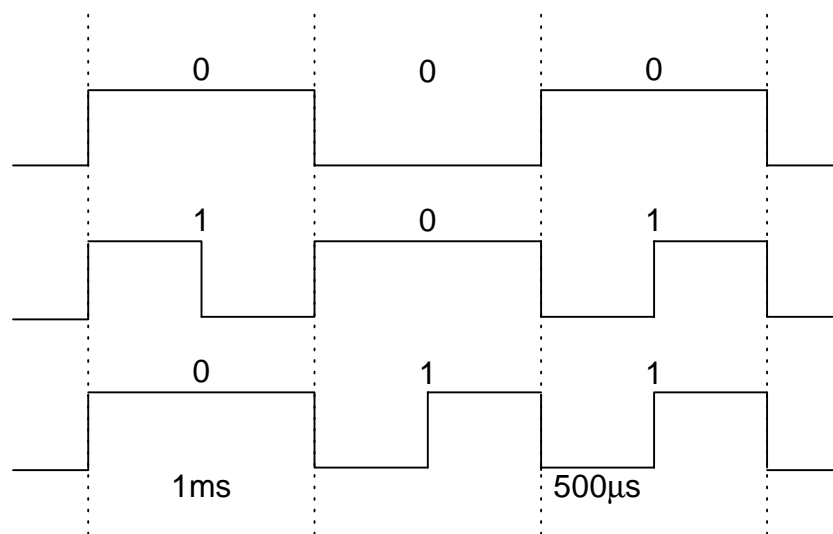

**Figure 4: 1kbps differential Manchester coding of '1' and '0'**

Control44 transmits a 6-byte burst, with 8 bits of preamble and 4 bits postamble. When firing up the transmitter from cold Control44 puts in an extra 55ms especially for Narrow Band FM transmitter and receiver requiring longer power-up to stable data time.

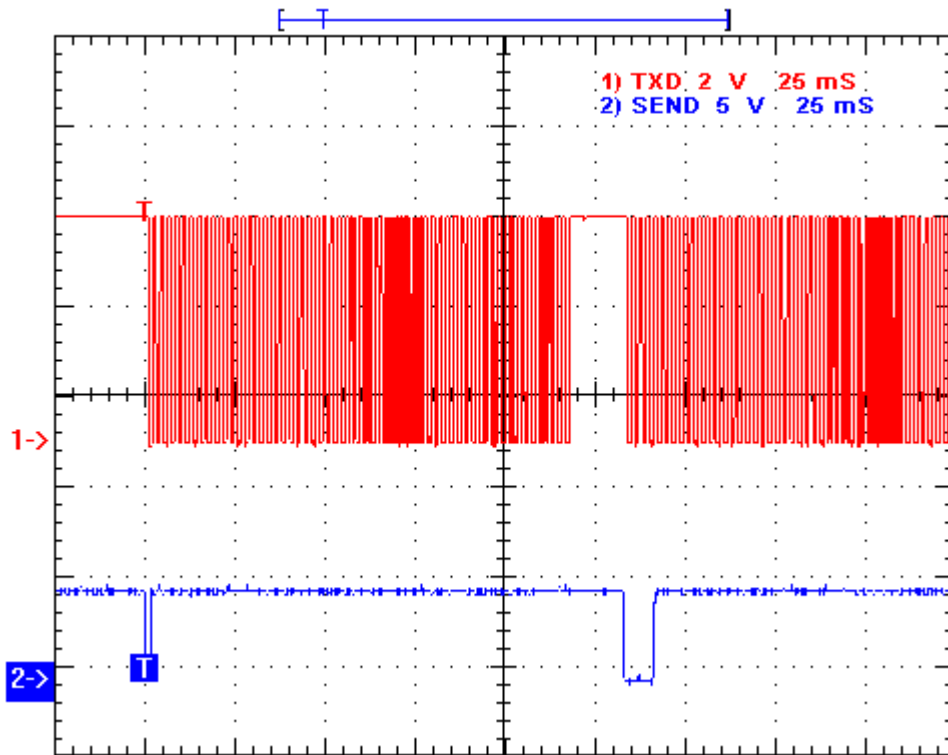

**Figure 5: Push button transmission with 55ms power-up preamble**

The large amount of sync code, address and checksum reduce the likelihood of false calling on noise to an insignificant degree, while the breaking up of the data sequences with bit7 zeros is to reduce the likelihood of the decoder mistaking particular sequences in the data for sync codes.

Differential Manchester encoding converts the 0000 into 11001100 which is the bit pattern equivalent to preamble required to settle adaptive data slicer in the RF receiver module.

Preamble = 11001100 this byte is not decoded.  
 Sync1 = 10111111  
 Sync2 = 111100(A7)(B7)  
 DataA = 0(DA6-DA0) Reserved for future use and custom variants  
 DataB = 0(DB6-DB0)  
 Address = 0(A5-A0)0  
 Checksum = sum of (DA7-DA0) + (DB7-DB0) + ADR(whole byte) truncated to 8 bits

This allows 6 bits of address and 2 data bytes per 60ms burst when 3.58MHz resonator is used.

	Preamble	Sync1	Sync2	Data A	Data B	Address	Check Sum	Postamble
0000000000000000	11001100	10111111	111100(DA7)(DB7)	0(DA6:DA0)	0(DB6:DB0)	0(A5:A0)0	DA7:DA0+DB7:DB0 +A7:A0	0000

**Figure 6: Control44 data packet**

In the following example, Control44 in Encoder mode is set with the following.

DB3	DB2	DB1	DB0	A3	A2	A1	A0
1	0	1	0	1	0	0	1

The Control44 will packetise the address and data into the following format. Reserved DataA is transmitted as 00hex. Any custom variants requiring more than 8 bits of data will make use of this slot.

Preamble	Sync1	Sync2	DataA	DataB	Address	Checksum	Postamble
----------	-------	-------	-------	-------	---------	----------	-----------

Preamble	Sync1	Sync2	DataA	DataB	Address	Checksum	Postamble
11001100	10111111	11110000	00000000	00001010	00010010	00011100	0000

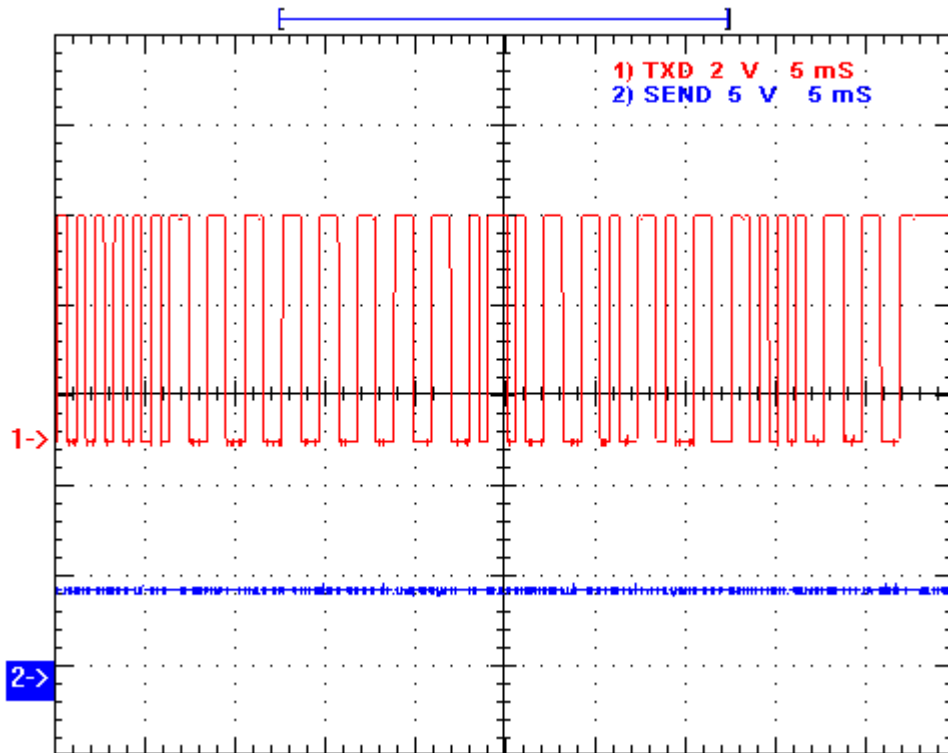

Figure 6: Synchronisation codes, DataA, DataB, Address, Checksum and Postamble

## Application Modes

Mode	Setup	Description
4 wires	Latch = 0V (connect) SEND = 0V (connect)	Continuous transmission like wire connection
Pushbutton	Latch = Vdd (connect) SEND = 0V (push button)	Decoder outputs active only when transmitter is keyed
Latched Pushbutton	Latch = 0V (connect) SEND = 0V (push button)	Decoder outputs hold state of last transmission

## Ordering Information

CTR44-000-SS	Control 44 ( $\leq 4$ MHz)- No Frequency - Shrink Small Outline
CTR44-000-SO	Control 44 ( $\leq 4$ MHz)- No Frequency - Small Outline
CTR44-000-DIL	Control 44 ( $\leq 4$ MHz)- No Frequency - Plastic Dual In Package
CTR44L-000-SS	Control 44 Low Voltage ( $\leq 4$ MHz) - No Frequency - Shrink Small Outline
CTR44L-000-SO	Control 44 Low Voltage ( $\leq 4$ MHz) - No Frequency - Small Outline
CTR44L-000-DIL	Control 44 Low Voltage ( $\leq 4$ MHz) - No Frequency - Plastic Dual In Package
CTR44H-000-SS	Control 44 High Speed (4MHz-20MHz) - No Frequency - Shrink Small Outline
CTR44H-000-SO	Control 44 High Speed (4MHz-20MHz) - No Frequency - Small Outline
CTR44H-000-DIL	Control 44 High Speed (4MHz-20MHz) - No Frequency - Plastic Dual In Package

# Appendix

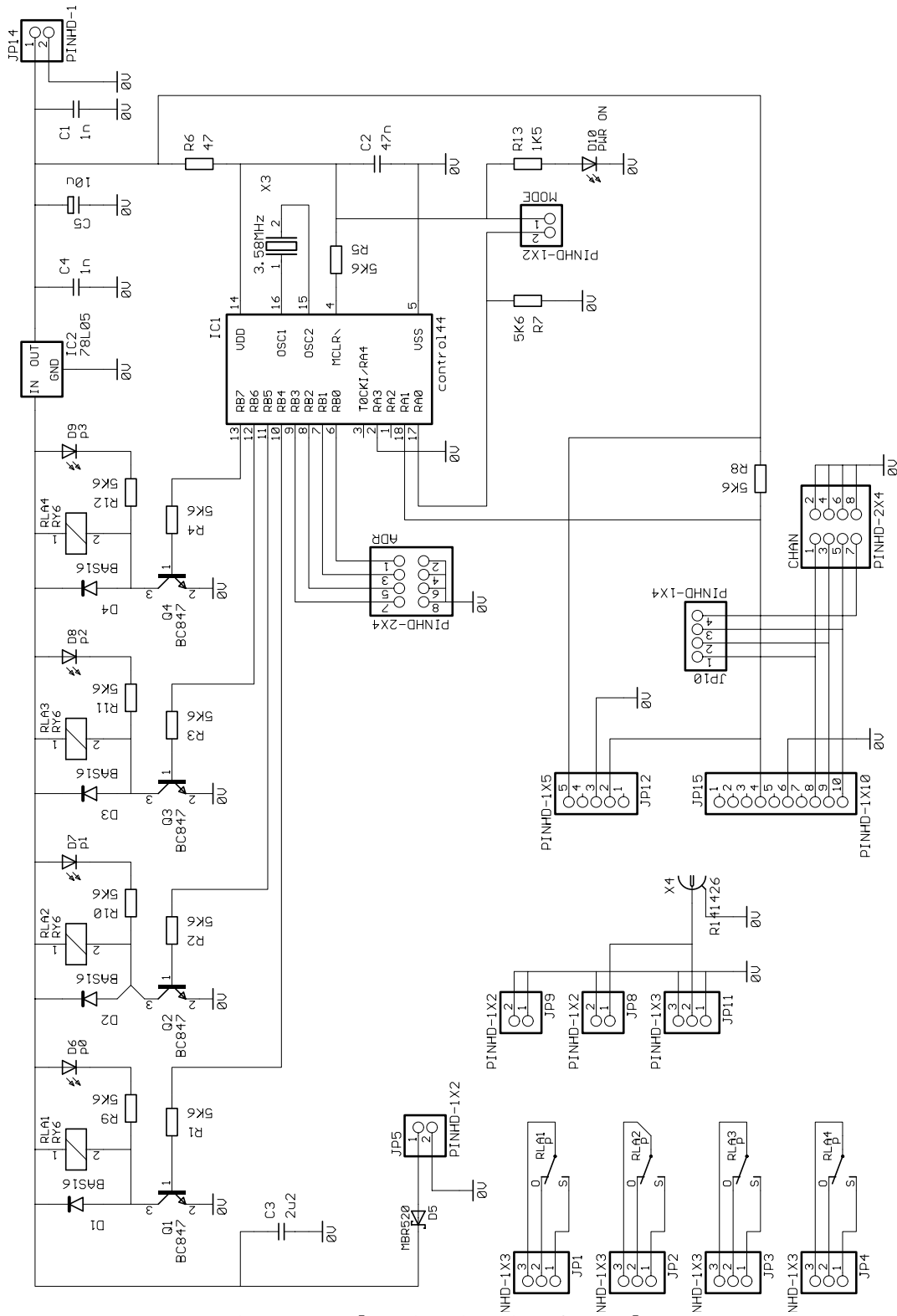

**Figure 7: Relay circuit using Control44**

It uses Schrack RY610012 or OKO K4M12 relay which is rated 8A @ 250V AC or 30V DC and runs off at 12VDC.

Control44 Evaluation Kit is also available to evaluate CTR44 with single frequency Radiometrix radio modules.

**Radiometrix Ltd**  
Hartcran House, Gibbs Couch  
Watford, WD19 5EZ, ENGLAND  
Tel: +44 (0)20 8428 1220  
Fax: +44 (0)20 8428 1221  
info@radiometrix.co.uk  
www.radiometrix.co.uk

### **Copyright notice**

*This product data sheet is the original work and copyrighted property of Radiometrix Ltd. Reproduction in whole or in part must give clear acknowledgement to the copyright owner.*

### **Limitation of liability**

*The information furnished by Radiometrix Ltd is believed to be accurate and reliable. Radiometrix Ltd reserves the right to make changes or improvements in the design, specification or manufacture of its subassembly products without notice. Radiometrix Ltd does not assume any liability arising from the application or use of any product or circuit described herein, nor for any infringements of patents or other rights of third parties which may result from the use of its products. This data sheet neither states nor implies warranty of any kind, including fitness for any particular application. These radio devices may be subject to radio interference and may not function as intended if interference is present. We do NOT recommend their use for life critical applications.*

*The Intrastat commodity code for all our modules is: 8542 6000*

### **R&TTE Directive**

*After 7 April 2001 the manufacturer can only place finished product on the market under the provisions of the R&TTE Directive. Equipment within the scope of the R&TTE Directive may demonstrate compliance to the essential requirements specified in Article 3 of the Directive, as appropriate to the particular equipment.*

*Further details are available on Radiocommunications Agency (RA) web site:*

**<http://www.radio.gov.uk/topics/conformity/conform-index.htm>**

The Library and Information Service  
The Radiocommunications Agency  
Wyndham House  
189 Marsh Wall  
London E14 9SX  
United Kingdom  
Tel: +44 (0)20 7211 0502/0505  
Fax: +44 (0)20 7211 0507  
library@ra.gsi.gov.uk

*For further information on radio matters  
contact the Agency's 24 Hour Telephone  
Enquiry Point. +44 (0)20 7211 0211*

European Radiocommunications Office (ERO)  
Midtermolen 1  
DK 2100 Copenhagen  
Denmark  
Tel. +45 35250300  
Fax +45 35250330  
ero@ero.dk  
www.ero.dk