

VHF Narrow Band FM Transmitter and Receiver

The TX1 and RX1 form a miniature VHF radio transmitter/receiver pair designed for PCB mounting and suitable for extended range data links at speeds up to 10kbps. Link ranges of 10km+ are achievable with suitable choice of data rate and antennas.



left: TX1 transmitter

Features:

- ◆ CE Certified by independent Notified Body
- ◆ Verified to comply with harmonised radio standard ETSI EN 300 220-3 and EMC standard ETSI EN 301 489-3 by accredited Test Laboratory
- ◆ Frequencies available as standard: 173.225MHz, 173.250MHz
- ◆ Other frequencies from 151.300MHz to 173.250MHz available to order
- ◆ Data rates up to 10 kbps with 25kHz channel spacing
- ◆ Usable range to 10km+
- ◆ Screened construction

Available for licence-exempt operation in the UK 173MHz bands, the TX1 & RX1 modules combine effective screening with internal filtering to minimise spurious radiation and susceptibility thereby ensuring EMC compliance. They are particularly suitable for one-to-one and multi-node wireless links where longer ranges are required at low to moderate data rates. Applications include building security, EPOS and inventory tracking, remote industrial process monitoring and data networks. Because of their small size and low power consumption, both modules are ideal for use in battery-powered portable applications such as hand-held terminals.

Transmitter - TX1

- ◆ 2 stage crystal controlled, NBFM modulated at up to 10 kb/s
- ◆ Operation from 2.2V to 12V @ 9.5mA
- ◆ Built-in regulator for improved stability and supply noise rejection
- ◆ Exceptional power efficiency, typically 35% DC → RF @ 3V supply
- ◆ +10dBm (10mW) RF output
- ◆ Harmonics typically -70dBc
- ◆ Enable facility

Receiver - RX1

- ◆ Single conversion NBFM superhet
- ◆ Image rejection >50dB
- ◆ Operation from 2.7V to 12V @ 12mA
- ◆ Built-in regulator for improved stability and supply noise rejection
- ◆ 10kbps, -116dBm sensitivity @ 1ppm BER
- ◆ RSSI output with >80dB range
- ◆ Local oscillator leakage <-60 dBm
- ◆ Enable facility

Functional description

The TX1 module is a two stage crystal controlled NBFM transmitter operating between 2.2V and 12V at a current of 9.5mA. At 3V supply it delivers nominally +10dBm RF output. The SIL style TX1 measures 32 x 12 x 3.8 mm excluding the pins.

The RX1 module is a single conversion NBFM superhet receiver capable of handling data rates of up to 10kbps. It will operate from a supply of 2.7V to 12V and draws 12mA when receiving. A signal strength (RSSI) output with greater than 80dB of range is provided. The SIL style RX1 measures 48 x 17.5 x 5.5 mm excluding the pins.

TX1 transmitter

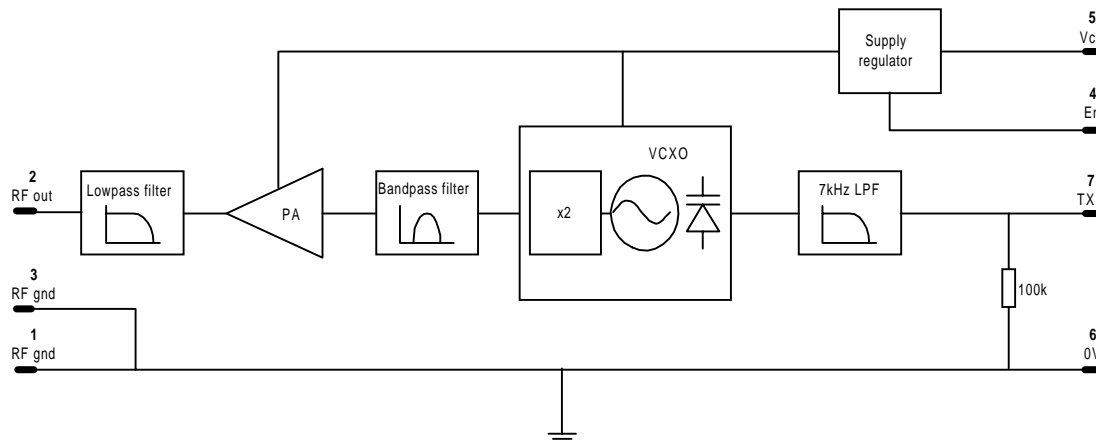

Fig.1: TX1 block diagram

Pin description

RF gnd (pins 1 & 3)

RF ground, internally connected to the module screen and pin 6 (0V). These pins should be directly connected to the RF return path - e.g. coax braid, main PCB ground plane etc.

RF out (pin 2)

50Ω RF output to antenna. Internally DC-isolated. See antenna section of applications notes for details of suitable antennas / feeds.

En (pin 4)

Tx enable. $\leq 0.15V$ on this pin disables module (current $< 1\mu A$), $\geq 1.7V$ enables module. Input impedance $1M\Omega$ approx. Observe slew rate requirements (see applications notes).

Vcc (pin 5)

DC +ve supply. Max ripple content $0.1V_{P-P}$. Decoupling is not generally required.

0V (pin 6)

DC supply ground. Internally connected to pins 1, 3 and module screen.

TXD (pin 7)

DC-coupled modulation input. Accepts serial digital data at 0V to 3V levels. See applications notes for suggested drive methods. Input impedance $100k\Omega$ nominal.

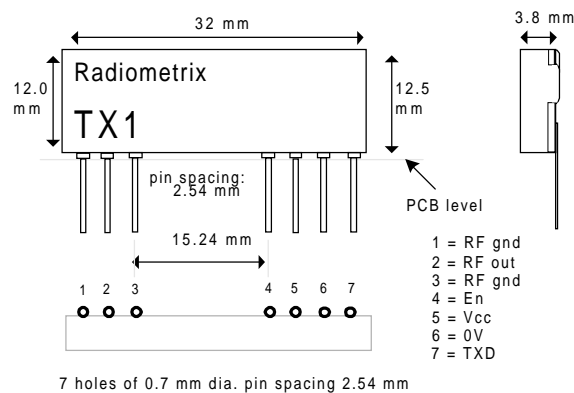

Fig.2: TX1 physical dimensions

RX1 receiver

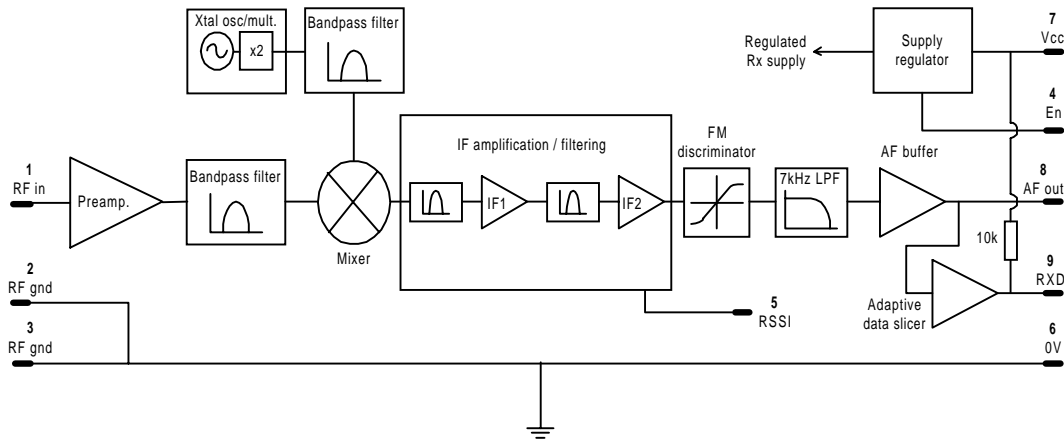

Fig.3: RX1 block diagram

Pin description

RF in (pin 1)

50Ω RF input from antenna. Internally DC-isolated. See antenna section of applications notes for suggested antennas and feeds.

RF gnd (pins 2 & 3)

RF ground, internally connected to the module screen and pin 6 (0V). These pins should be directly connected to the RF return path - e.g. coax braid, main PCB ground plane etc.

En (pin 4)

Rx enable. $\leq 0.15V$ on this pin disables module (current $< 1\mu A$), $\geq 1.7V$ enables module. Input impedance $1M\Omega$ approx. Observe slew rate requirements (see applications notes).

RSSI (pin 5)

Received Signal Strength Indicator with $>80dB$ range. See applications notes for typical characteristics.

0V (pin 6)

DC supply ground. Internally connected to pins 2, 3 and module screen.

Vcc (pin 7)

DC +ve supply. Max ripple content $0.1V_{P-P}$. Decoupling is not generally required.

AF out (pin 8)

Buffered and filtered analogue output from the FM demodulator. It has a standing DC bias of 1V and $400mV_{P-P}$ baseband signal. Useful as a test point or to drive external decoders (see applications notes). External load should be $>1k\Omega // <100pF$.

RXD (pin 9)

Digital output from internal data slicer (squared version of the signal on pin 8). It may be used to drive external decoders. The data is true data, i.e. as fed to the transmitter. Output is "open-collector" format with internal $10k\Omega$ pullup to Vcc (pin 7).

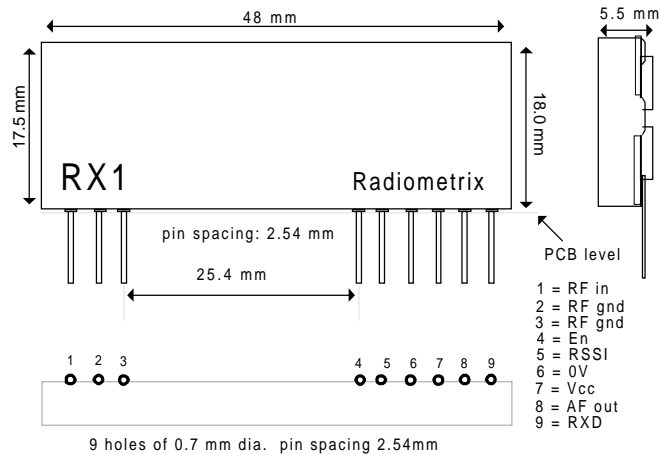

Fig.4: RX1 physical dimensions

Absolute maximum ratings

Exceeding the values given below may cause permanent damage to the module.

| | |
|-----------------------|-----------------|
| Operating temperature | -20°C to +60°C |
| Storage temperature | -40°C to +100°C |

TX1

| | |
|---------------------|--------------------------------|
| Vcc, TXD (pins 5,7) | -0.3V to +16.0V |
| En (pin 4) | -0.3V to +Vcc V |
| RF out (pin 2) | ±50V @ <10MHz, +20dBm @ >10MHz |

RX1

| | |
|---------------------------|--------------------------------|
| Vcc, RXD (pins 7,9) | -0.3V to +16.0V |
| En, RSSI, AF (pins 4,5,8) | -0.3V to +Vcc V |
| RF in (pin 1) | ±50V @ <10MHz, +13dBm @ >10MHz |

Performance specifications: TX1 transmitter (Vcc = 3.0V / temperature = 20°C unless stated)

| | pin | min. | typ. | max. | units | notes |
|------------------------------|-----|------|------|-------|-------|-------|
| <i>DC supply</i> | | | | | | |
| Supply voltage | 5 | 2.2 | 3.0 | 12 | V | |
| Supply current | 5 | | 9.5 | 11 | mA | |
| <i>RF</i> | | | | | | |
| RF power output @ Vcc = 2.2V | 2 | +4.5 | +6 | +7.5 | dBm | 1 |
| RF power output @ Vcc ≥ 2.8V | 2 | +8.5 | +10 | +11.5 | dBm | 1 |
| Spurious emissions | 2 | | -70 | -55 | dBc | 2 |
| Frequency accuracy | | -2.0 | 0 | +2.0 | kHz | 3 |
| FM deviation (peak) | | ±2.5 | ±3.0 | ±3.5 | kHz | 4 |
| <i>Baseband</i> | | | | | | |
| Modulation bandwidth @ -3dB | | 0 | | 7 | kHz | |
| Modulation distortion (THD) | | | 10 | 15 | % | 7 |
| TXD input level (logic low) | 7 | -0.2 | 0 | 0.2 | V | 5,7 |
| TXD input level (logic high) | 7 | 2.8 | 3.0 | 3.2 | V | 5,7 |
| <i>Dynamic timing</i> | | | | | | |
| Power-up time (En → full RF) | | | 2 | 5 | ms | 6,7 |

Notes:

1. Measured into 50Ω resistive load.
2. Exceeds EN/EMC requirements at all frequencies.
3. Total over full supply and temperature range.
4. With 0V – 3.0V modulation input.
5. To achieve specified FM deviation.
6. Dependent upon TXD conditions during power-up.
7. See applications information for further details.

Performance specifications: RX1 receiver
(Vcc = 3.0V / temperature = 20°C unless stated)

| | pin | min. | typ. | max. | units | notes |
|--------------------------------------|------|------|-------|------|-------------------|-------|
| DC supply | | | | | | |
| Supply voltage | 7 | 2.7 | 3.0 | 12 | V | |
| Supply current | 7 | | 12 | 14 | mA | |
| RF/IF | | | | | | |
| RF sensitivity @ 10dB (S+N)/N | 1, 8 | | -119 | -115 | dBm | |
| RF sensitivity @ 1ppm BER | 1, 9 | | -116 | -112 | dBm | |
| IP ₃ at RF input | 1 | | -28 | | dBm | |
| RSSI threshold | 1, 5 | | -127 | | dBm | 1 |
| RSSI range | 1, 5 | 80 | 90 | | dB | 1 |
| IF bandwidth | | | 15 | | kHz | |
| Image rejection | 1 | 50 | 55 | | dB | |
| Adjacent channel rejection | 1 | 50 | 55/60 | | dB | 2 |
| Spurious response rejection | 1 | 70 | 100 | | dB | |
| LO leakage, conducted | 1 | | -70 | -65 | dBm | 3 |
| LO leakage, radiated | | | -70 | -60 | dBm | 3 |
| Baseband | | | | | | |
| Baseband bandwidth @ -3dB | 8 | 0.05 | | 6 | kHz | 1, 4 |
| AF level | 8 | | 400 | | mV _{P-P} | 5 |
| DC offset on AF out | 8 | 0.7 | 1.0 | 1.3 | V | |
| Distortion on recovered AF | 8 | | 1 | 10 | % | |
| Load capacitance, AFout / RXD | 8, 9 | | | 100 | pF | |
| Dynamic timing | | | | | | |
| <i>Power up with signal present</i> | | | | | | |
| Power up to valid RSSI | 4, 5 | | 4 | 5 | ms | |
| Power up to stable data | 4, 9 | | 16 | 20 | ms | |
| <i>Signal applied with supply on</i> | | | | | | |
| Signal to valid RSSI | 1, 5 | | 0.4 | 0.6 | ms | |
| Signal to stable data | 1, 9 | | 4 | 12 | ms | 6 |
| Time between data transitions | 9 | 1.8 | | 0.1 | ms | 7 |
| Mark : space ratio | 9 | 20 | 50 | 80 | % | 8 |

Notes:

1. See applications information for further details.
2. Typically 55dB @ +25kHz offset, 60dB @ -25kHz offset.
3. Exceeds EN/EMC requirements at all frequencies.
4. Lower limit can be extended to DC if required, by means of external circuitry.
5. For received signal with ±3kHz FM deviation.
6. Typically 4ms for signal at channel centre, maximum 12ms at ±4kHz RF offset.
7. For 50:50 mark to space ratio (i.e. squarewave).
8. Average over 50ms period at maximum bit rate.

Module test circuits

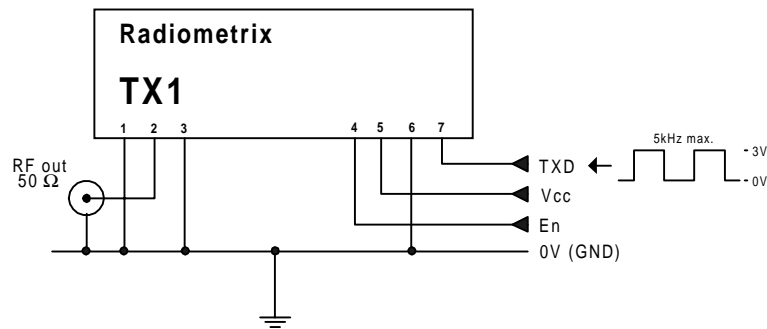

Fig.5: TX1 test circuit

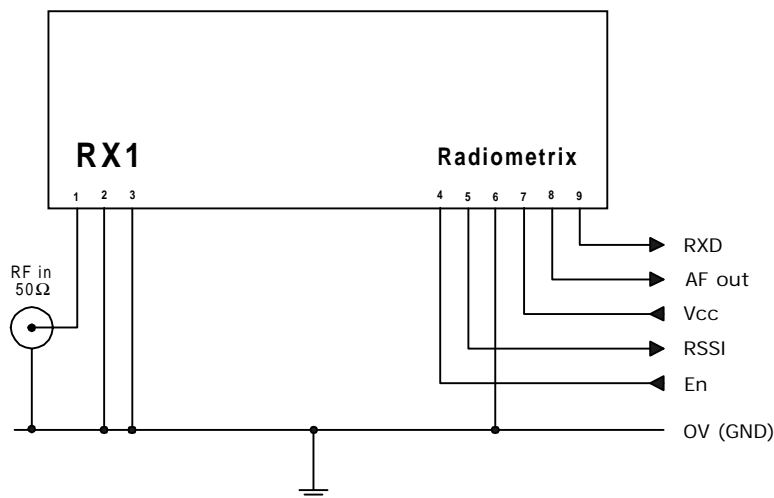

Fig.6: RX1 test circuit

Applications information

Power supply requirements

Both modules have built-in regulators which deliver a constant 2.85V to the module circuitry when the external supply voltage is 2.9V or greater, with 40dB or more of supply ripple rejection. This ensures constant performance up to the maximum permitted rail, and removes the need for external supply decoupling except in cases where the supply rail is extremely poor (ripple/noise content $>0.1V_{p-p}$).

Note, however, that for supply voltages lower than 2.85V the regulator is effectively inoperative and supply ripple rejection is considerably reduced. Under these conditions the ripple/noise on the RX1 supply rail should be below $20mV_{p-p}$ to avoid problems. If the quality of the supply is in doubt, it is recommended that a $10\mu F$ tantalum or similar capacitor be added between pin 7 of the module (Vcc) and ground together with a 10Ω series feed resistor between pin 7 and the supply rail.

The Enable pin allows the module to be turned on or off under logic control with a constant DC supply to the Vcc pin. The module current in power-down mode is less than $1\mu A$.

NOTE: If this facility is used, the logic control signal must have a slew rate of $40mV/\mu s$ or more. Slew rates less than this value may cause erratic operation of the on-board regulator and therefore the module itself.

The Enable pin should be tied directly to the Vcc pin if this facility is not required.

TX1 modulation requirements

The module is factory-set to produce the specified FM deviation with a TXD input to pin 7 of 3V amplitude, i.e. 0V “low”, 3V “high”. Reducing the amplitude of the data input from this value (usually as a result of reducing the supply voltage) reduces the transmitted FM deviation to typically $\pm 2.5\text{kHz}$ at the lower extreme of 2.2V. The receiver will cope with this quite happily and no significant degradation of link performance should be observed as a result.

Where the module supply is greater than 3V a resistor must be added in series with the TXD input to limit the modulation amplitude to a maximum of 3V on pin 7. TXD input resistance is 100k Ω to ground, giving typical required resistor values as follows:

| Vcc | Series resistor |
|------------------|------------------------|
| $\leq 3\text{V}$ | - |
| 3.3V | 10 k Ω |
| 5V | 68k Ω |
| 9V | 220k Ω |

It should be noted that conditions on TXD have a significant effect on the startup time of the module, i.e. the time between En (or En+Vcc) going high and full RF output being produced. For fastest startup TXD should either be low or fed with data (preamble etc) for a minimum of 3ms after En has been asserted. Startup time under these conditions is typically 50-70% of that obtained if TXD is held high over the same period.

Reducing the output power of the TX1

If the TX1-173.250-10 is to be used for other than industrial/commercial applications its output power must be reduced to 1mW to comply with type approval requirements. This is done by inserting a 10dB attenuator network between the module and the antenna or feed, as follows:

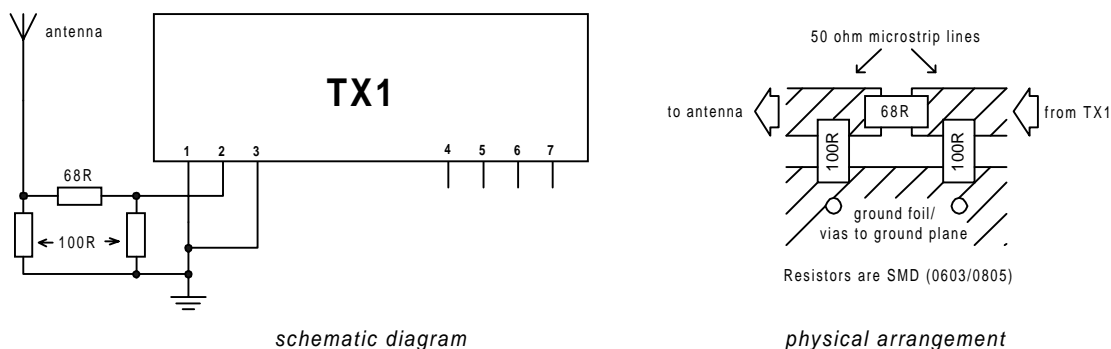

Fig. 7: 10dB attenuator for TX1

Keep all tracking around the attenuator network as short as possible, particularly ground paths, and use matched 50 Ω microstrip lines for input and output connections (track width of 2.5mm if using 1.6mm thick FR4 PCB).

RX1 Received Signal Strength Indicator (RSSI)

The RX1 receiver incorporates a wide range RSSI which measures the strength of an incoming signal over a range of 80dB or more. This allows assessment of link quality and available margin and is useful when performing range tests.

The output on pin 5 of the module has a standing DC bias of 0.15V-0.4V (0.25V typ.) with no signal, rising to 1.0-1.3V (1.15V typ.) at maximum indication. $\Delta V_{\min-\max}$ is typically 0.9V and is largely independent of standing bias variations. Output impedance is 10k Ω . Pin 5 can drive a 100 μ A meter directly, for simple monitoring.

Typical RSSI characteristic is as shown below:

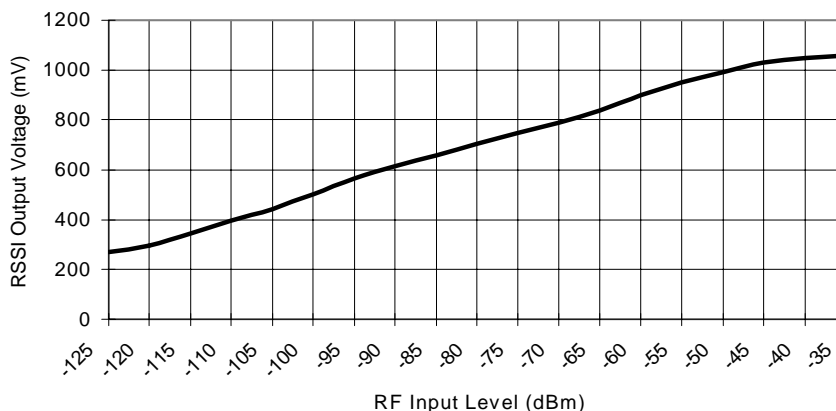

Fig.8: RSSI response curve

To ensure a reasonably fast response the RSSI line has limited internal decoupling of 11nF to ground. This results in a small amount of audio ripple on the DC output at pin 5 of the module. If this is a problem further decoupling may be added at the expense of response speed, in the form of a capacitor from pin 5 to ground. For example, adding an extra 0.1 μ F on this pin will increase the RSSI response time to around 4ms.

Expected range

Predicting the range obtainable in any given situation is notoriously difficult since there are many factors involved. The main ones to consider are as follows:

- Type and location of antennas in use (see pages 10-12)
- Type of terrain and degree of obstruction of the link path
- Sources of interference affecting the receiver
- “Dead” spots caused by signal reflections from nearby conductive objects
- Data rate and degree of filtering employed (see page 9)

The following are typical examples – but range tests should ***always*** be performed before assuming that a particular range can be achieved in a given situation:

| Data rate | Tx antenna | Rx antenna | Environment | Range |
|------------------|-------------------|-------------------|--------------------|--------------|
| 1.2kbps | half-wave | half-wave | rural/open | 10-15km |
| 10kbps | half-wave | half-wave | rural/open | 3-4km |
| 10kbps | helical | half-wave | urban/obstructed | 500m-1km |
| 10kbps | helical | helical | in-building | 100-200m |

Note: The figure for 1.2kbps assumes that the receiver bandwidth has been suitably reduced by utilising an outboard audio filter/data slicer or similar arrangement. If the RX1 is used “as is” the range will be similar to that for 10kb/s.

Data formats and range extension

The TX1 data input is normally driven directly by logic levels but will also accept analogue drive (e.g. 2-tone signalling). In this case it is recommended that TXD (pin 7) be DC-biased to 1.2V approx. with the modulation ac-coupled and limited to a maximum of $2V_{p-p}$ to minimise distortion over the link. The varactor modulator in the TX1 introduces some 2nd harmonic distortion which may be reduced if necessary by predistortion of the analogue waveform. At the other end of the link the RX1 AF output is used to drive an external decoder directly.

Although the modulation bandwidth of the TX1 extends down to DC, as does the AF output of the RX1, it is not advisable to use data containing a DC component. This is because frequency errors and drifts between the transmitter and receiver occur in normal operation, resulting in DC offset errors on the RX1 audio output.

The RX1 in standard form incorporates a low pass filter with a 6kHz nominal bandwidth. In conjunction with similar filtering in the TX1 an overall system bandwidth of 5kHz is obtained. This is suitable for transmission of data at raw bit rates up to 10kb/s. A lower rolloff frequency of around 50Hz has been chosen for the internal filter and data slicer in order to keep receiver settling times reasonably fast. This results in a lowest usable data speed of about 1kb/s for the standard module.

In applications such as long range fixed links where data speed is not of prime concern, a considerable increase in range can be obtained by using the slowest possible data rate together with filtering to reduce the receiver bandwidth to the minimum necessary. The internal data slicer is not suitable for data having longer than 1.8ms between transitions and in such circumstances the RX1 audio output can be utilised to drive an external filter and data slicer.

The RX1 produces an audio output of approximately $400mV_{p-p}$ at pin 8, but due to the internal filtering this exhibits a rolloff at low frequencies giving a reduced output of some $100mV_{p-p}$ as DC is approached. This rolloff can be eliminated and a flat response to DC obtained by using an external RC compensation network, as follows:

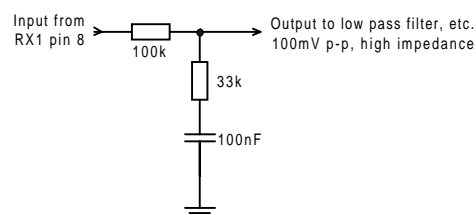

Fig.9: Audio compensation network

The output of the network will be flat from DC to 5kHz+. It will have a standing DC bias of 1V approx. and should not be significantly loaded (input impedance of following stage should ideally be $\geq 1M\Omega$).

Antennas

The choice and positioning of transmitter and receiver antennas is of the utmost importance and is the single most significant factor in determining system range. The following notes are intended to assist the user in choosing the most effective antenna type for any given application.

Integral antennas

These are relatively inefficient compared to the larger externally-mounted types and hence tend to be effective only over limited ranges. They do however result in physically compact equipment and for this reason are often preferred for portable applications. Particular care is required with this type of antenna to achieve optimum results and the following should be taken into account:

1. Nearby conducting objects such as a PCB or battery can cause detuning or screening of the antenna which severely reduces efficiency. Ideally the antenna should stick out from the top of the product and be entirely in the clear, however this is often not desirable for practical/ergonomic reasons and a compromise may need to be reached. If an internal antenna must be used try to keep it away from other metal components and pay particular attention to the "hot" end (i.e. the far end) as this is generally the most susceptible to detuning. The space around the antenna is as important as the antenna itself.
2. Microprocessors and microcontrollers tend to radiate significant amounts of radio frequency hash which can cause desensitisation of the receiver if its antenna is in close proximity. The problem becomes worse as logic speeds increase, because fast logic edges generate harmonics across the VHF range which are then radiated effectively by the PCB tracking. In extreme cases system range may be reduced by a factor of 5 or more. To minimise any adverse effects situate antenna and module as far as possible from any such circuitry and keep PCB track lengths to the minimum possible. A ground plane can be highly effective in cutting radiated interference and its use is strongly recommended.

A simple test for interference is to monitor the receiver RSSI output voltage, which should be the same regardless of whether the microcontroller or other logic circuitry is running or in reset.

The following types of integral antenna are in common use:

Quarter-wave whip. This consists simply of a piece of wire or rod connected to the module at one end. At 173MHz the total length should be 410mm from module pin to antenna tip including any interconnecting wire or tracking. Because of the length of this antenna it is almost always external to the product casing.

Helical. This is a more compact but slightly less effective antenna formed from a coil of wire. It is very efficient for its size, but because of its high Q it suffers badly from detuning caused by proximity to nearby conductive objects and needs to be carefully trimmed for best performance in a given situation. The size shown is about the maximum commonly used at 173MHz and appropriate scaling of length, diameter and number of turns can make individual designs much smaller.

Loop. A loop of PCB track having an inside area as large as possible (minimum about 5cm²), tuned and matched with 2 capacitors. Loops are relatively inefficient but have good immunity to proximity detuning, so may be preferred in shorter range applications where high component packing density is necessary.

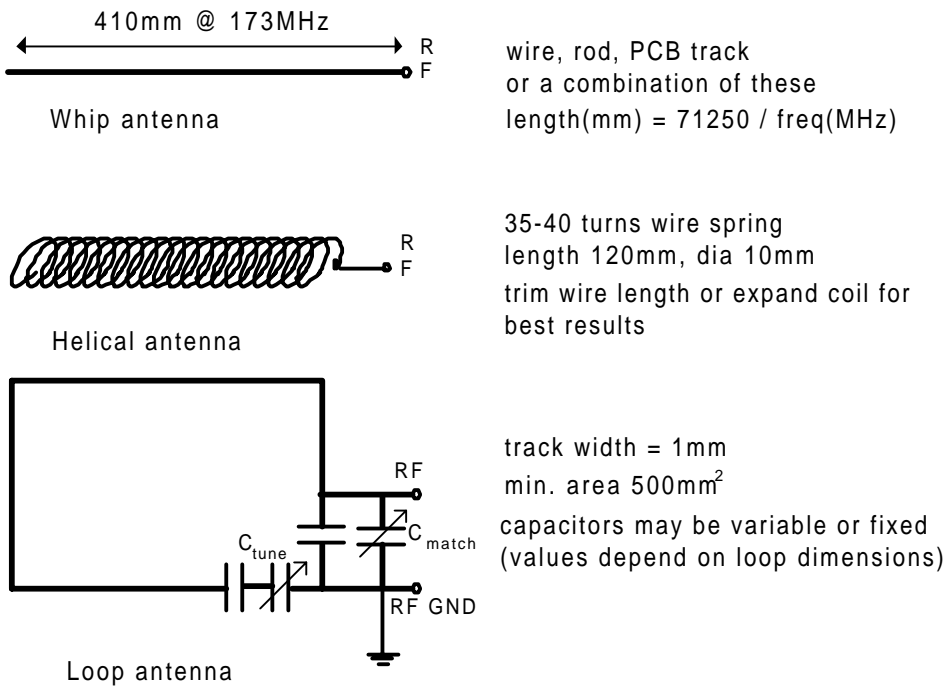

Fig.10: integral antenna configurations

Integral antenna summary:

| | whip | helical | loop |
|-------------------------------|------|---------|------|
| Ultimate performance | *** | ** | * |
| Ease of design set-up | *** | ** | * |
| Size | * | *** | ** |
| Immunity to proximity effects | ** | * | *** |

Tamper-proof integral antenna

Where the RX1 is used in alarm applications it may sometimes be necessary to provide a warning if any attempt is made to remove or disable its antenna. A typical solution to this problem is as follows:

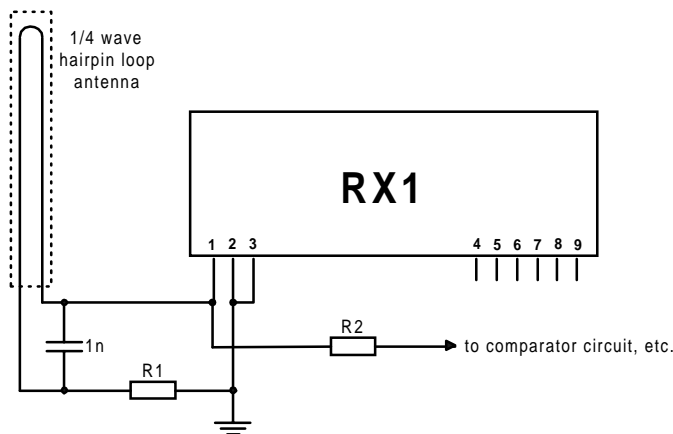

Fig.11: Tamper-proof antenna arrangement

In normal operation the output will have a resistance to ground of R1+R2. If the antenna is shorted to ground it will show R2 only, and if the antenna is cut it will be open-circuit. R1 and R2 may be any value over 1kΩ. All track lengths should be kept to a minimum and the output may need to be decoupled in some cases to avoid noise being injected into the antenna from the following circuitry.

External antennas

These have several advantages if portability is not an issue, and are essential for long range links. External antennas can be optimised for individual circumstances and may be mounted in relatively good RF locations away from sources of interference, being connected to the equipment by coax feeder.

Helical. Of similar dimensions and performance to the integral type mentioned above, commercially-available helical antennas normally have the coil element protected by a plastic moulding or sleeve and incorporate a coax connector at one end (usually a straight or right-angle BNC type). These are compact and simple to use as they come pre-tuned for a given application, but are relatively inefficient and are best suited to shorter ranges.

Quarter-wave whip. Again similar to the integral type, the element usually consists of a stainless steel rod or a wire contained within a semi-flexible moulded plastic jacket. Various mounting options are available, from a simple BNC connector to wall brackets, through-panel fixings and magnetic mounts for temporary attachment to steel surfaces.

A significant improvement in performance is obtainable if the whip is used in conjunction with a metal ground plane. For best results this should extend all round the base of the whip out to a radius of 300mm or more (under these conditions performance approaches that of a half-wave dipole) but even relatively small metal areas will produce a worthwhile improvement over the whip alone. The ground plane should be electrically connected to the coax outer at the base of the whip. Magnetic mounts are slightly different in that they rely on capacitance between the mount and the metal surface to achieve the same result.

A ground plane can also be simulated by using 3 or 4 quarter-wave radials equally spaced around the base of the whip, connected at their inner ends to the outer of the coax feed. A better match to a 50Ω coax feed can be achieved if the elements are angled downwards at approximately 30-40° to the horizontal.

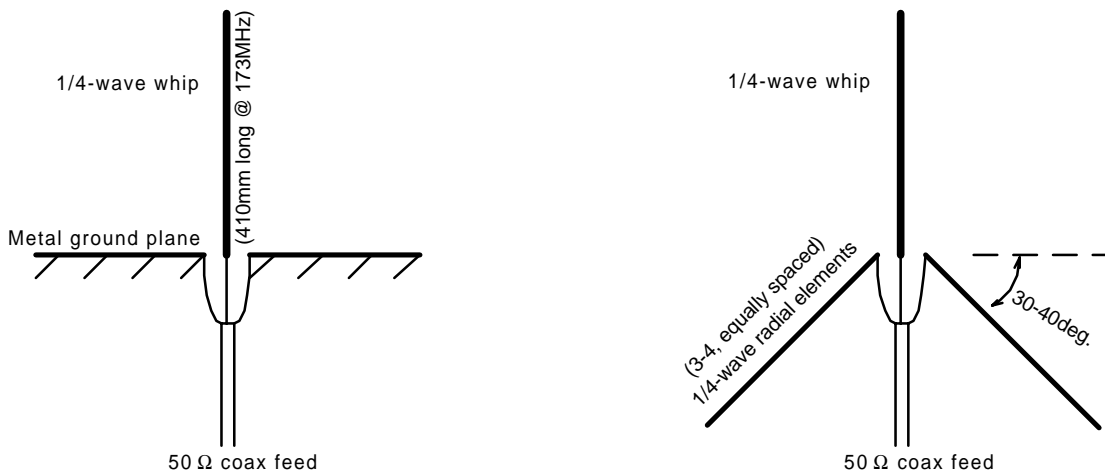

Fig.12: Quarter wave antenna / ground plane configurations

Half-wave. There are two main variants of this antenna, both of which are very effective and are recommended where long range and all-round coverage are required:

- 1.** The half-wave dipole consists of two quarter-wave whips mounted in line vertically and fed in the centre with coaxial cable. The bottom whip takes the place of the ground plane described previously. A variant is available using a helical instead of a whip for the lower element, giving similar performance with reduced overall length. This antenna is suitable for mounting on walls etc. but for best results should be kept well clear of surrounding conductive objects and structures (ideally >1m separation).
- 2.** The end-fed half wave is the same length as the dipole but consists of a single rod or whip fed at the bottom via a matching network. Mounting options are similar to those for the quarter-wave whip. A ground plane is sometimes used but is not essential. The end-fed arrangement is often preferred over the centre-fed dipole because it is easier to mount in the clear and above surrounding obstructions.

Yagi. This antenna consists of two or more elements mounted parallel to each other on a central boom. It is directional and exhibits gain but tends to be large and unwieldy – for these reasons the yagi is the ideal choice for links over fixed paths where maximum range is desired.

Please note: Using a Yagi or other gain antenna with the TX1 will exceed the maximum radiated power permitted by UK type approval regulations. It can be used in the UK **only** in conjunction with the RX1 receiver.

For best range in UK fixed link applications use a half-wave antenna on transmit and a half-wave or Yagi on receive, both mounted as high as possible and clear of obstructions.

The above antennas may be obtained from several sources in the UK, for example:

R W Badland Ltd
Unit 3
Providence Street
Lye
Stourbridge
West Midlands
DY9 8HN
England
Tel. +44 (0)1384 423160
Fax +44 (0)1384 423958 / 895051
info@badland.co.uk
www.badland.co.uk

Renair Antennae Ltd.
11-15 Chase Road
Park Royal
London NW10 6PT
England
Tel: +44 (0)20 8965 3001
Fax: +44 (0)20 8965 5773
sales@renair.co.uk
www.renair.co.uk

Module mounting considerations

The modules may be mounted vertically or bent horizontal to the motherboard. Note that the four components mounted on the underside of the RX1 are relatively fragile – avoid direct mechanical contact between these and other parts of the equipment if possible, particularly in situations where extreme mechanical stresses could routinely occur (as a result of equipment being dropped onto the floor, etc).

Good RF layout practice should be observed. If the connection between module and antenna is more than about 20mm long use 50Ω microstrip line or coax or a combination of both. It is desirable (but not essential) to fill all unused PCB area around the module with ground plane.

Variants and ordering information

The TX1 transmitter and RX1 receiver are manufactured in the following variants as standard:

For alarm applications on 173.225MHz:

| | |
|-----------------------|-------------|
| TX1-173.225-10 | Transmitter |
| RX1-173.225-10 | Receiver |

For general applications on 173.250MHz:

| | |
|-----------------------|-------------|
| TX1-173.250-10 | Transmitter |
| RX1-173.250-10 | Receiver |

Other variants can be supplied to individual customer requirements at frequencies from 151.300MHz to 173.250MHz and/or optimised for specific data speeds and formats. Please consult the factory for further information.

Type approval

The TX1 module is type approved to European harmonised standard ETSI EN 300 220-3 for UK use within the following categories:

- (a) General applications in the band 173.2-173.35MHz but **excluding** 173.225MHz.
- (b) Industrial/commercial applications at the same frequencies as category (a).
- (c) Fixed/in-building alarm applications at 173.225MHz.
- (d) Medical/biological applications (including airborne use for the tracking of birds) in the band 173.7-174.0MHz.

REQUIREMENTS FOR CONFORMANCE TO ETSI EN 300 220-3:

1. Transmitted ERP (effective radiated power) must not exceed the limit of 1mW (0dBm) for category (a) or 10mW (+10dBm) for categories (b), (c) and (d). Equipment in category (a) must include a 10dB attenuator between the TX1 RF output pin and the antenna or feed, as specified on page 7 of this leaflet.
2. Any type of antenna system may be employed provided that the applicable ERP limit is not exceeded - i.e. transmitting antenna structures which exhibit ERP gain (such as yagis) are not permitted. See pages 10-13 of this leaflet for details of suitable antennas.
3. The module must not be modified or used outside its specification limits.
4. The module may only be used to transmit digital or digitised data. Speech and/or music are not permitted.

Breaching any of these conditions will invalidate type approval.





CERTIFICATE OF CONFORMANCE FROM RADIO FREQUENCY INVESTIGATION LTD.

Test Of: Radiometrix Ltd
TX1

To: EN 301 489-1 V1.2.1 (2000-08)
according to the specific conditions
detailed in EN 301 489-3 V1.2.1 (2000-08)
(requested parts only)

Certificate of Conformance Serial No:
RFI/EMCB1/TC42137ETF11A

| | | |
|--|---|---|
| <p>This is to certify that a sample of the equipment defined above has been tested by Radio Frequency Investigation Ltd. (Basingstoke) to the above standard as detailed in RFI report number RFI/EMCB1/TS42137ETF11A . In the configuration tested the equipment was compliant with the standard or parts of the standard applied to the sample.</p> <p>For full details please refer to document RFI/EMCB1/TS42137ETF11A</p> | | |
| Tested By:  | Approved Signatory:  | |
| Certificate Copy No: PDF01 | Test Item Receipt Date: 11 June 2001 | |
| Issue Date: 25 July 2001 | Test Date: 02 July 2001 | |
| Issued to: Radiometrix Ltd Hartcran House Gibbs Couch Carpenders Park Watford WD1 5EZ Hertfordshire | Deviations from tested standard: None. | |
| <p>This certificate may be reproduced in full. Partial reproduction may only be made with the written consent of Radio Frequency Investigation Ltd. This certificate applies only to the sample(s) tested.</p> | | |
| Radio Frequency Investigation Ltd, Ewhurst Park, Ramsdell, Basingstoke, Hampshire, RG26 5RQ, ENGLAND. Tel: +44 (0) 1256 851193 Fax: +44 (0) 1256 851192 | Registered in England, No. 211 7901. Registered Office: Ewhurst Park, Ramsdell, Basingstoke, Hampshire RG26 5RQ |  0644 |

CE Certificate for TX1-151.300-10 and its variants



Radio Frequency Investigation Ltd

NOTIFIED BODY OPINION RFI/NBCB1/RP42627JD07

Applicants Details

Applicant's Company Name: Radiometrix Ltd
Address: Hartcran House, Gibbs Couch, Carpenters Park, Watford, Herts.
WD1 5EZ
Contact Name: Mr S. Paramanathan

Manufacturers Details

Manufacturer's Company Name: Radiometrix Ltd
Address: Hartcran House, Gibbs Couch, Carpenters Park, Watford, Herts.
WD1 5EZ
Contact Name: Mr S. Paramanathan

Product Details

Product Name: TX1-151.300-10
Model Number(s): TX1-151.300-10
TX1-173.250-10
TX1-173.225-10
TCF Reference Number: RM/TX1/DTD
Standard(s): EN 300 220-1 V1.3.1 (2000-09) according to the requirements of EN
300 220-3 V1.1.1 (2000-09)
Description: VHF Narrow Band FM Data Transmitter Module

In the opinion of RFI, the Technical Construction File demonstrates that the Apparatus to which it relates conforms to the essential requirements of Article 3.2 of Council Directive 1999/5/EC on radio equipment and telecommunications terminal equipment and the mutual recognition of their conformity. The Apparatus can only be used with a half wavelength antenna, loop antenna and helical antenna.

Authorised Signatory:

A handwritten signature in black ink, appearing to read 'N Cobb', is written over a horizontal line.

Mr N Cobb

16-10-01

Date



Company Seal

Notified Body Number - 0889

Radio Frequency Investigation Ltd, Ewhurst Park, Ramsdell, Basingstoke, Hampshire RG26 5RD, ENGLAND
Tel: +44 (0) 1256 851193 Fax: +44 (0) 1256 851192 E-mail: sales@rfi.co.uk
Registered in England, No. 211 7901

CE Certificate for RX1-151.300-10 and its variants



Radio Frequency Investigation Ltd

NOTIFIED BODY OPINION RFI/NBCB2/42627JD08

Applicants Details

Applicant's Company Name: Radiometrix Ltd
Address: Hartcran House, Gibbs Couch, Carpenders Park, Watford, Herts.,
WD19 5EZ
Contact Name: Mr K. Ravenhill

Manufacturers Details

Manufacturer's Company Name: Radiometrix Ltd
Address: Hartcran House, Gibbs Couch, Carpenders Park, Watford, Herts.,
WD19 5EZ
Contact Name: Mr K. Ravenhill

Product Details

Product Name: RX1
Model Number(s): RX1-151.300-10
RX1-173.250-10
RX1-173.225-10
TCF Reference Number: RM/RX1/DTD
Standard(s): EN 300 220-1 V1.3.1 (2000-09) according to the requirements of EN
300 220-3 V1.1.1 (2000-09)
Description: VHF Narrow Band FM Data Receive Module

In the opinion of RFI, the Technical Construction File demonstrates that the Apparatus to which it relates conforms to the essential requirements of Article 3.2 of Council Directive 1999/5/EC on radio equipment and telecommunications terminal equipment and the mutual recognition of their conformity.

Authorised Signatory:



Mr N Cobb

1-11-01

Date



Notified Body Number - 0889

Company Seal

Radio Frequency Investigation Ltd, Exhurst Park, Ramsdell, Basingstoke, Hampshire RG26 5RQ, ENGLAND
Tel: +44 (0) 1256 851193 Fax: +44 (0) 1256 851192 E-mail: sales@rfi.co.uk
Registered in England, No. 211 7901

Radiometrix Ltd

Hartcran House
Gibbs Couch
Watford
WD19 5EZ
ENGLAND

Tel: +44 (0)20 8428 1220

Fax: +44 (0)20 8428 1221

info@radiometrix.co.uk

www.radiometrix.co.uk

Copyright notice

This product data sheet is the original work and copyrighted property of Radiometrix Ltd. Reproduction in whole or in part must give clear acknowledgement to the copyright owner.

Limitation of liability

The information furnished by Radiometrix Ltd is believed to be accurate and reliable. Radiometrix Ltd reserves the right to make changes or improvements in the design, specification or manufacture of its subassembly products without notice. Radiometrix Ltd does not assume any liability arising from the application or use of any product or circuit described herein, nor for any infringements of patents or other rights of third parties which may result from the use of its products. This data sheet neither states nor implies warranty of any kind, including fitness for any particular application. These radio devices may be subject to radio interference and may not function as intended if interference is present. We do NOT recommend their use for life critical applications.

The Intrastat commodity code for all our modules is: 8542 6000

R&TTE Directive

After 7 April 2001 the manufacturer can only place finished product on the market under the provisions of the R&TTE Directive. Equipment within the scope of the R&TTE Directive may demonstrate compliance to the essential requirements specified in Article 3 of the Directive, as appropriate to the particular equipment.

Further details are available on Radiocommunications Agency (RA) web site:

<http://www.radio.gov.uk/topics/conformity/conform-index.htm>

The Library and Information Service
The Radiocommunications Agency
Wyndham House
189 Marsh Wall
London
United Kingdom
E14 9SX
Tel: +44 (0)20 7211 0502/0505
Fax: +44 (0)20 7211 0507
library@ra.gsi.gov.uk

*For further information on radio matters
contact the Agency's 24 Hour Telephone
Enquiry Point: +44 (0)20 7211 0211*

European Radiocommunications Office (ERO)
Midtermolen 1
DK 2100 Copenhagen
Denmark
Tel. +45 35250300
Fax +45 35250330
ero@ero.dk
www.ero.dk