

STE s.a.s. ELETTRONICA TELECOMUNICAZIONI
Via Maniago N.15 - 20134 - Milano - Italy
Tel.: +39.02.2153524 / 2153525 / 2157891 Fax: +39.02.26410928
www.stecom.com ste@stecom.com

**PLL NBFM SYNTHESIZED VOICE/DATA TRANSCEIVER
868 - 870 MHz ISM BAND**

BK78



OPERATING AND SERVICE MANUAL

General Description

The BK78A5 and the BK78B5 are “PLL” synthesized UHF transceivers for use in Wireless “Voice” (Analogue Signal) or “Data” transmission applications.

The transceivers operate on the 868-870 MHz SRD Band and are designed to comply to the European Standards EN 300-220-3 (class I) and EN 301-489-3.

The transceivers employ NBFM (Narrow Band Frequency Modulation) with a 25 KHz channel separation. The programming frequency step is 12.5 KHz.

A) BK78A5

The BK78A5 is designed in accordance with CEPT-ERC/REC 70-03 recommendation (Annex 1 – Non specific short range devices) for applications employing a 10 mW or 25 mW max radiated power (ERP).

B) BK78B5

The BK78B5 has 500 mW output RF power (100mW in “ Low Power”) and it is programmable from 868 MHz to 870 MHz .

It is designed for operation in the sub-band I (869.40-869.65 MHz).

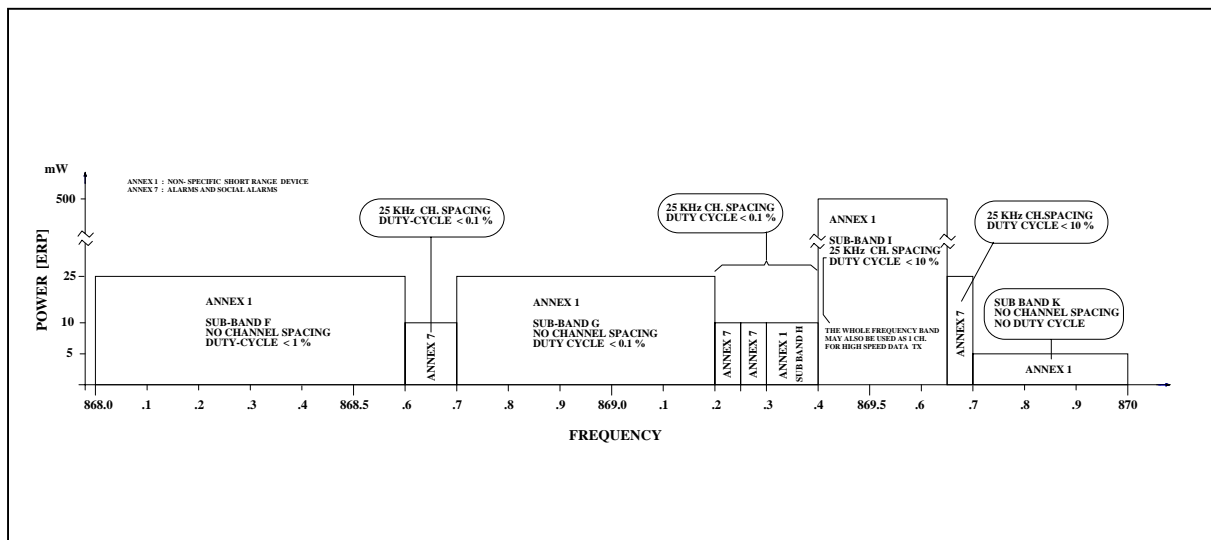

Fig. 1 CEPT ERC/REC 70-03 SRD 868 MHz Band.

BK78A5 – BK78B5 Specifications					
	Min	Typ	Max	Units	Notes
GENERAL					
FREQUENCY RANGE	867.000		871.000	MHz	(1)
CHANNEL SPACING		25		KHz	
FREQUENCY PROGR. STEP		12.5		KHz	
FREQUENCY STABILITY		±2.5	±3	ppm	(2)
ANTENNA IMPEDANCE		50		Ω	
DATA RATE (DATA MODE)	1200		9600	Baud	
FREQ. RESPONSE (VOICE MODE)	100		7000	Hz	
SUPPLY VOLTAGE	4.75	5	5.25	V	
SUPPLY CURRENT - Rx MODE		35	40	mA	
SUPPLY CURRENT - Tx MODE : a) BK78A5 (100 mW) b) BK78B5 (500 mW)		100 250		mA mA	
OPERATING TEMPERATURE	- 20		+ 60	°C	
DIMENSIONS	95 x 50 x 7.5 mm				
WEIGHT	25 g				
TRANSMITTER					
RF OUTPUT POWER : a) BK78A5 low high b) BK78B5 low high	20 80 80 400	35 100 100 500		mW mW mW mW	(3)
SPURIOUS EMISSION		-40	- 36	dBm	
FM DEVIATION		3	5	KHz	
R/T SWITCHING TIME		5	10	ms	(4)
MODULATION : VOICE MODE (PM MOD.) VOICE MODE (FM MOD.) DATA MODE (GMSK MOD.)	100 50 DC		3000 5000 4800	Hz Hz Hz	(5)
RECEIVER					
SENSITIVITY : VOICE MODE (PM MOD.) VOICE MODE (FM MOD.) DATA MODE (4800 Baud)		-120 -115 -110		dBm dBm dBm	(6) (6) (7)
SELECTIVITY	65	70		dB	(8)
IMAGE REJECTION		50		dB	
DYNAMIC RANGE	100	110		dB	
BLOCKING	+84	+85		dB	(9)
T/R SWITCHING TIME		5	10	ms	(4)
NOTE :					
(1) CEPT SRD BAND LIMITS = 868 – 870 MHz			(4) PLL LOCK-UP TIME		
(2) OVER OPERATING TEMPERATURE RANGE			(5) SQUARE WAVE 0-5 Vdc LEVEL		
(3) CEPT MAX ERP SUB BAND F (868-868.6 MHz) = 25 mW			(6) 12dB SINAD – 1KHz dev. 3KHz		
CEPT MAX ERP SUB BAND G (868.7-869.2 MHz) = 25 mW			(7) 1/10E2 BER		
CEPT MAX ERP SUB BAND I (869.4-869.65 MHz) = 500 mW			(8) ADJACENT CHANNEL SELECTIVITY		
CEPT MAX ERP SUB BAND K (869.7-870 MHz) = 5 mW			(9) Fc ± 1 MHz		

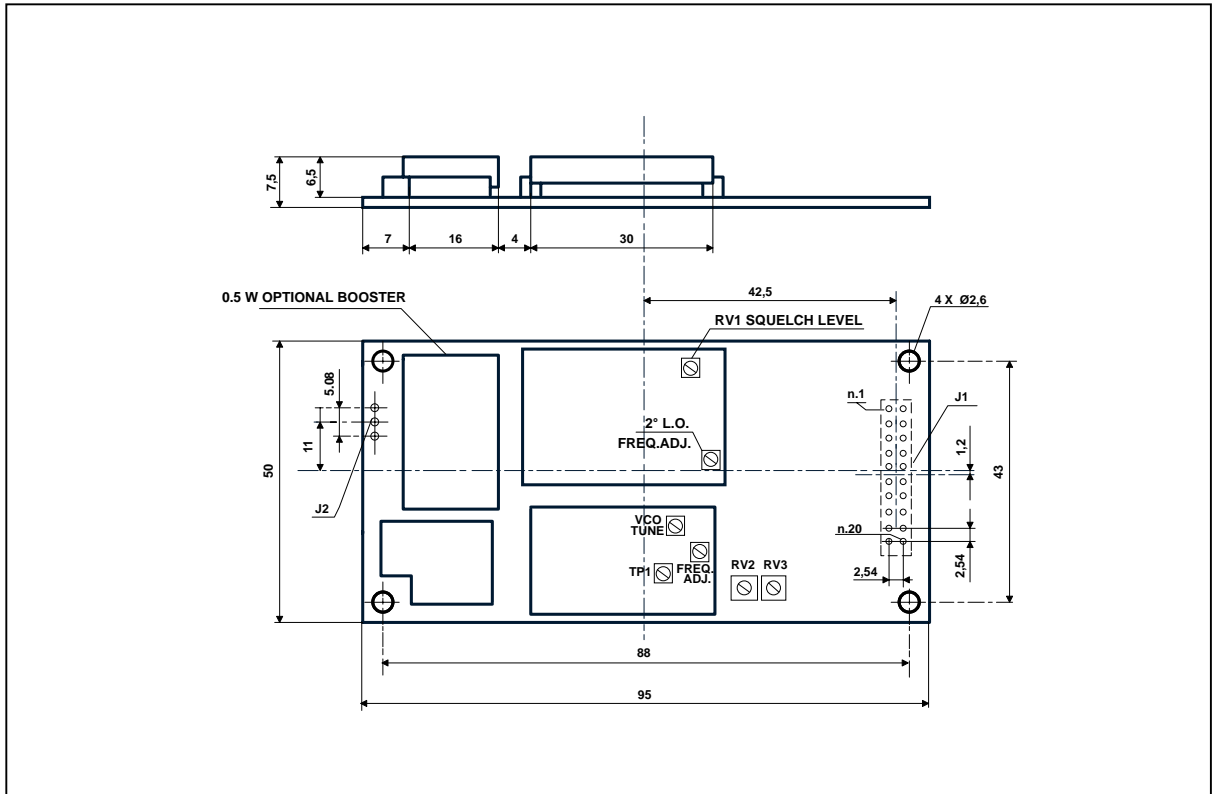

Fig. 3 - Physical dimensions

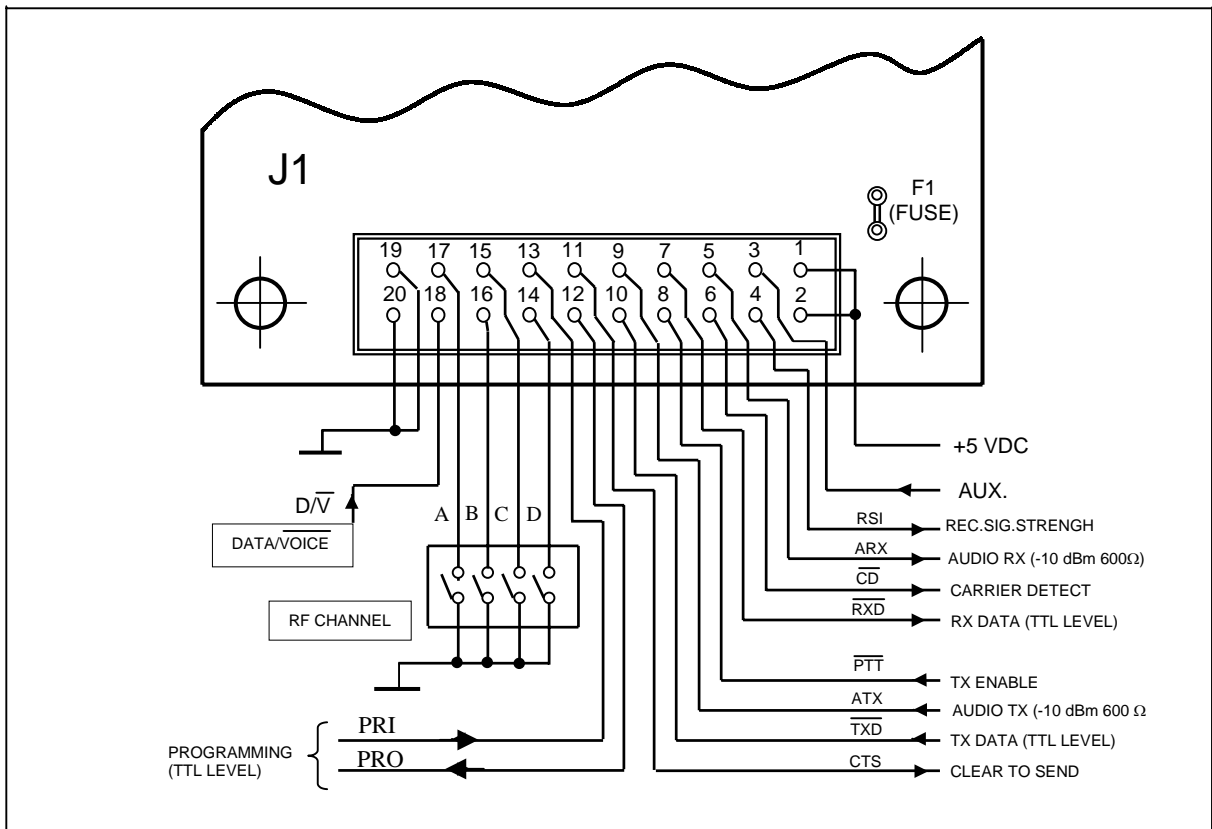

Fig. 4 - J1 connector

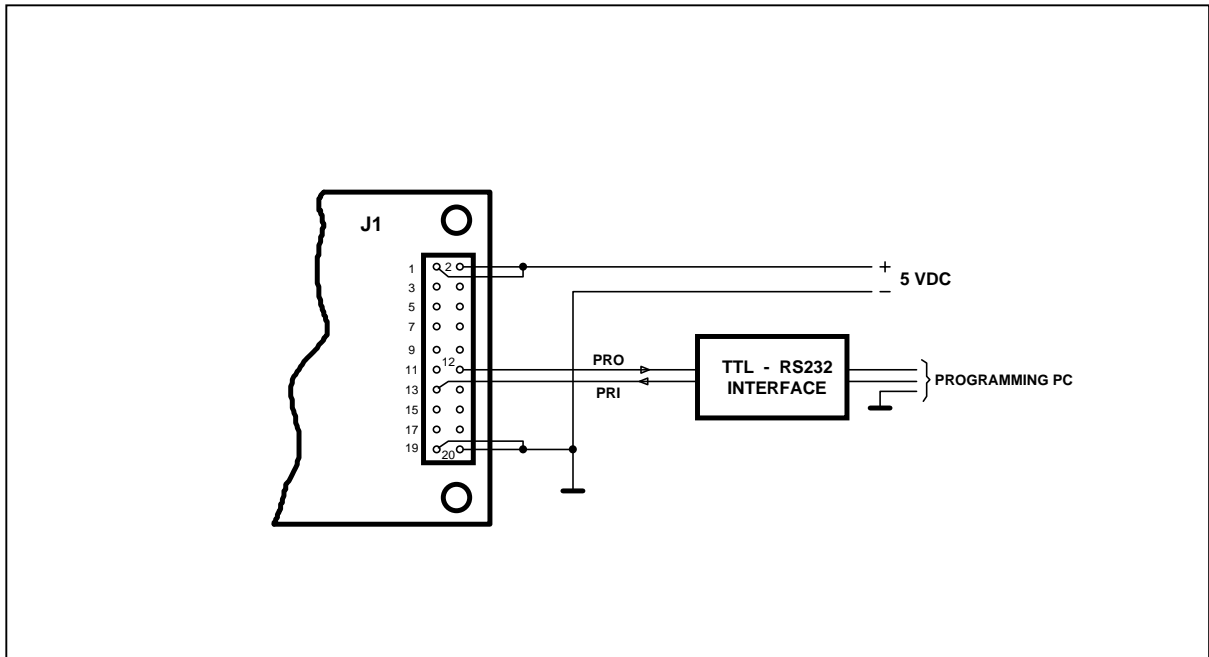

Fig. 5 PC "COM" port connection to program channels and TX power (HI/LO).

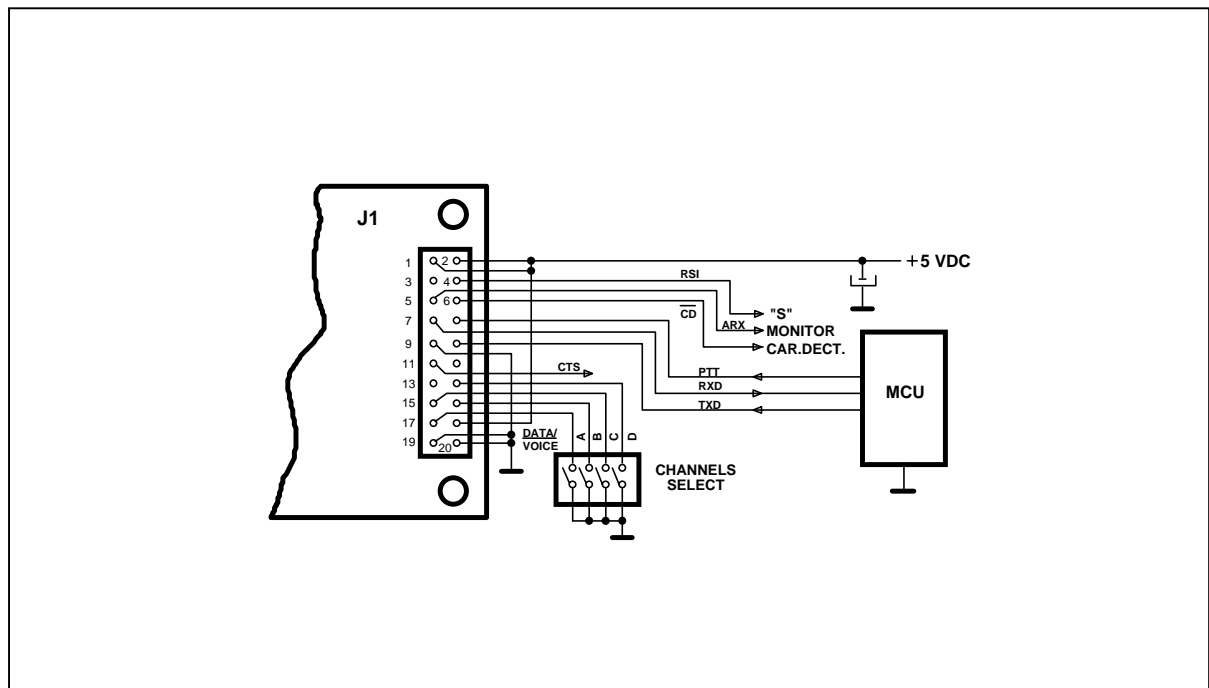

Fig. 6 "MCU" to transceiver typical connection ("Data" mode).

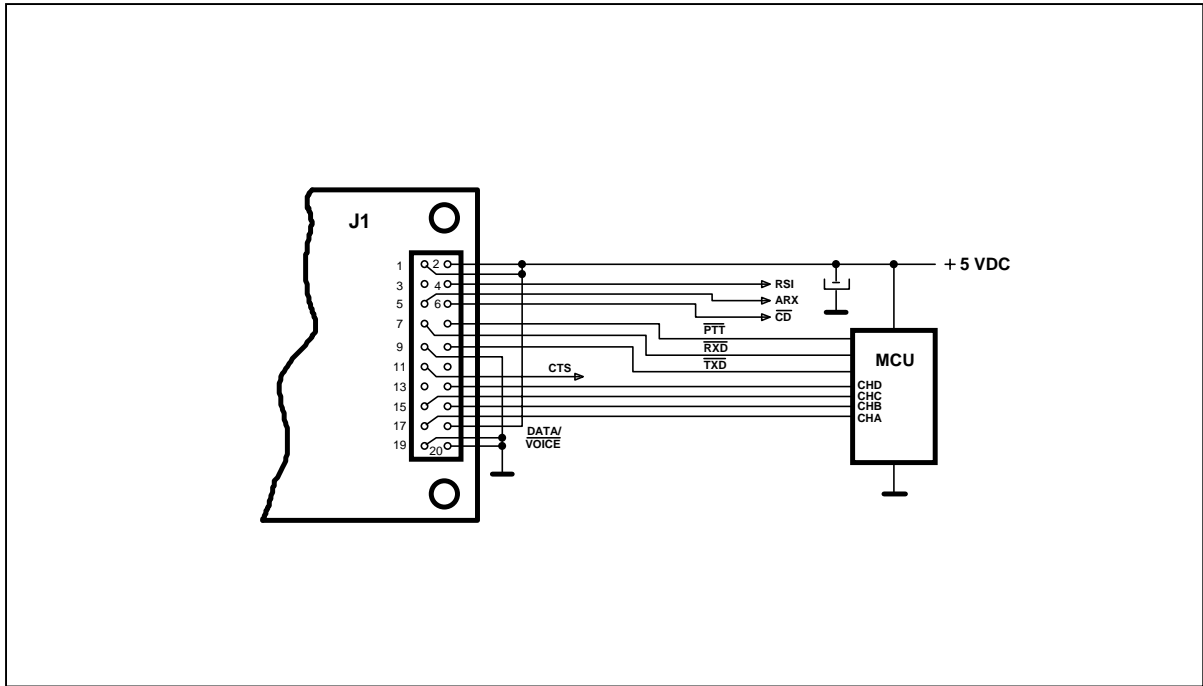

Fig. 7 “MCU” to transceiver typical connection (“Data” mode) with channel parallel programming.

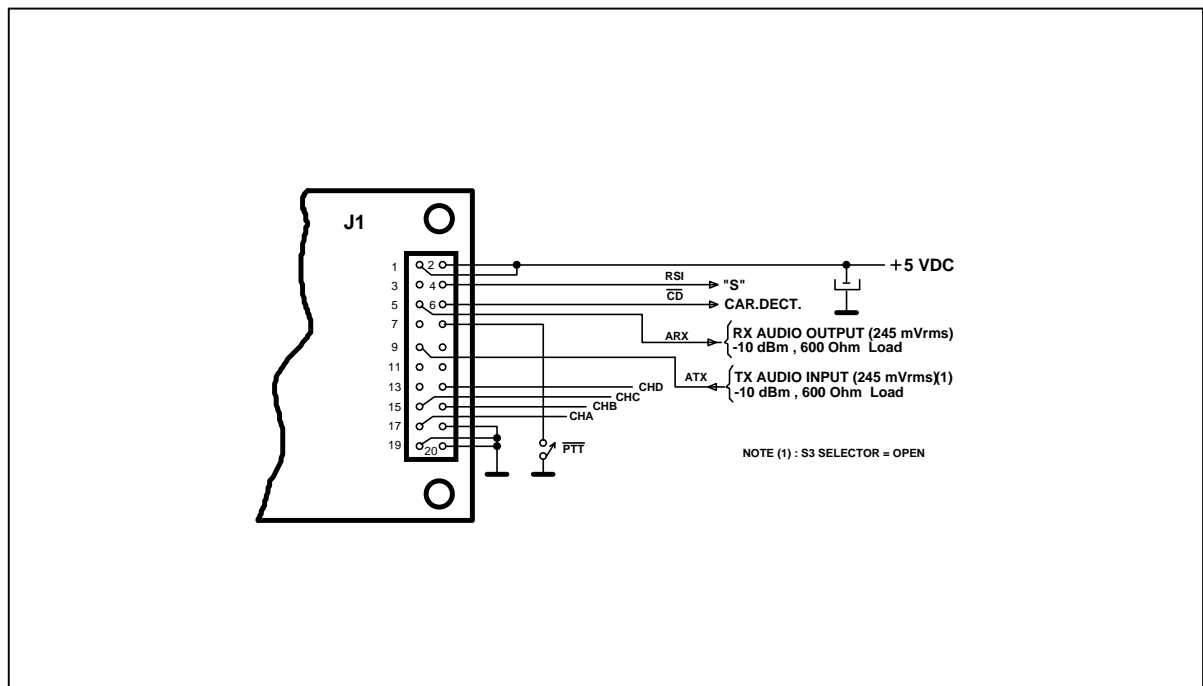

Fig. 8 Typical transceiver connections in “Voice” mode (analogue signals).

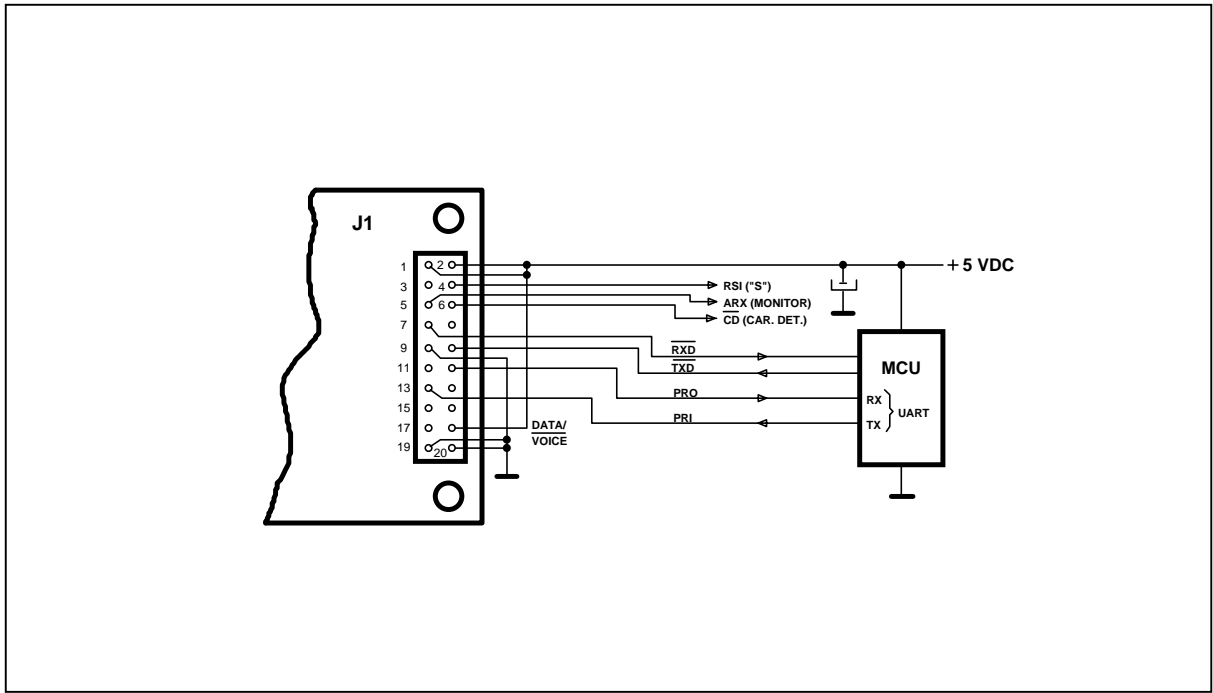

Fig. 9 Transceiver total control ("DATA" mode) by external host microcontroller (TX,RX, frequency, power).

DATA/VOICE input ($\overline{D/V}$ - J1 pin n.18)

The transceiver has two main operating modes, depending on $\overline{D/V}$ input :

1) $\overline{D/V}$ = Low (0 V)

“Voice” (analogue) signals can be transmitted with narrow band frequency modulation (NBFM).

Depending on the selectors S2 and S4 (“A” or “B” position), PM (phase modulation with 6 dB/oct emphasis) or FM (frequency modulation with flat frequency deviation) can be selected.

PM , with an optimum audio response from 300 Hz to 3KHz, is best suited for voice or telephone grade signals (DTMF, AFSK slow speed Modems, selective call, etc.) and has the best “S/N” ratio with an Rx sensitivity of - 120 dBm (12 dB SINAD).

FM with 3 KHz fixed deviation can be the best choice for audio signals ranging from 50 Hz to 5 KHz (Fast Modems, V/F converters, etc.).

Receiver sensitivity is -110 dBm (12 dB S/N).

Note : During “Voice” operating mode the Tx data input (TXD) is disabled .

2) $\overline{D/V}$ = High (5 V).

Digital Data can be transmitted (max data rate = 9600 Baud) and the modulation system is changed to “GMSK”.

The transceiver employs a Two Point Modulation system (VCO plus PLL Reference Oscillator – see block diagram Fig. 2) to provide a flat response from 4.8 KHz down to DC.

During “DATA” operating mode the TX has only two discrete transmitted frequencies :

Bit “0” (“ \overline{TXD} ” input = 5V) corresponds to a transmitted frequency $F_L = F_c - 3KHz$

Bit “1” (“ \overline{TXD} ” input = 0V) corresponds to a transmitted frequency $F_H = F_c + 3KHz$

(F_c is the nominal RF channel center frequency).

Note : In “DATA” operating mode the TX “VOICE” analog input “ATX” (J1- pin n.9) is not disabled. Signal on “ATX” input must be avoided.

PRO, PRI (J1 pins n.12-13) programming input-output

CH A-B-C-D (J1 pins n.14-15-16-17) channel select input

PRI and PRO are connected to the IC10 microcontroller USART input-output (see block diagram Fig.2) and are used to program the transmit and receive frequencies and the TX output RF power (“High” or “Low”).

Refer to Fig.5 for the programming set-up.

Sixteen channels can be programmed and stored in the IC10 EEPROM memory.

In operation one of the 16 channels is selected using parallel control lines $\overline{\text{CHA}}$, $\overline{\text{CHB}}$, $\overline{\text{CHC}}$ and $\overline{\text{CHD}}$ (negative logic).

The transceiver can be also programmed (Through PRI and PRO) during normal operation on default channel n.1 .Serial mode programming software is available for the BK7XX transceiver – for further details contact the STE sales office.

TABLE 1

CHANNEL	$\overline{\text{CHD}}$	$\overline{\text{CHC}}$	$\overline{\text{CHB}}$	$\overline{\text{CHA}}$
1	1	1	1	1
2	1	1	1	0
3	1	1	0	1
4	1	1	0	0
“	“	“	“	“
“	“	“	“	“
15	0	0	0	1
16	0	0	0	0

Note : $\overline{\text{CHA}}$ - $\overline{\text{CHB}}$ - $\overline{\text{CHC}}$ - $\overline{\text{CHD}}$ inputs have internal pull-up (10 K Ω) to + 5 V.

IC10 (see Fig. 2) is a PIC16F870 flash microcontroller whose function is to control the general functions of the transceiver and to program the channel frequency (transmit or receive) in the “PLL” integrated circuit (IC11 –Fujitsu MB15E03SL).

The microcontroller has inside an EEPROM where are stored program configurations for up to 16 channels (transmit and receive frequency, in 12.5 KHz step , and RF output power).

One of these 16 channels is selected using parallel control lines via the terminals CHA,CHB,CHC and CHD of J1 connector

CTS output (J1 – pin n.11)

The CTS (Clear To Send) output has two functions :

- 1) In transmission and reception mode it indicates the “LOCK” (CTS = HIGH – 5Vdc) or “UNLOCK” (CTS = LOW) state of the PLL synthesizer.
- 2) In data transmission mode it can be used to inform the DTE (Data Terminal Equipment) that the DCE (Data Communication Equipment – the radio) is ready to accept data to be transmitted.

CD output (J1 –pin n.6) carrier detect

In reception mode the CD output indicates the presence of an RF carrier.

CD is an open collector active to ground output, with internal pull-up resistor (10 K Ω). The threshold level is adjusted by RV1 (Squelch Adj.) and maximum current sink is 30 mA.

RSI output (J1 – pin n. 4) received signal strenght

RSI is a received signal strenght output with more than 60 dB dynamic range (external load > 100 K Ω).

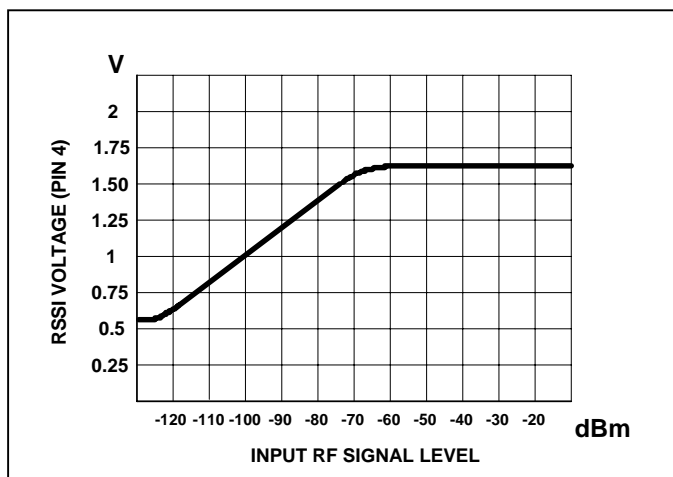

dBm to RF Volt conversion
 $Z_o = 50\Omega$ 0 dBm = 1 mV

dBm	RF mV	dBm	RF μ V
-20 dBm	22,4 mV	-80 dBm	22,4 μ V
-30 dBm	7,07 mV	-90 dBm	7,07 μ V
-40 dBm	2,24 mV	-100 dBm	2,24 μ V
-50 dBm	0,70 mV	-110 dBm	0,7 μ V
-60 dBm	0,22 mV	-120 dBm	0,22 μ V
-70 dBm	0,07 mV	-130 dBm	0,07 μ V

BK78x FREQUENCY-POWER PROGRAMMING

At “Power On” the radio memory (IC10 EEPROM) is loaded with the “ DEFAULT “ channels (see Table 2).

The radio can be programmed on different RF channels (TX frequency , RX frequency and TX output power level) via “PRI” and “PRO” terminals (J1 connector) connected to the serial “COM ” port of a “PC”.

“PRI” and “PRO” pins must be connected respectively to the “TD” and “RD” lines of the RS232 port with a suitable “TTL” to “RS232” driver (fig. 10).

Data are exchanged between the radio and the “PC” as “ASCII” characters : programs such as “HyperTerminal” can be used to send and receive the “ASCII” strings of characters.

Serial protocol format : 9600 Baud , 8 data bit , 1 stop , no parity .

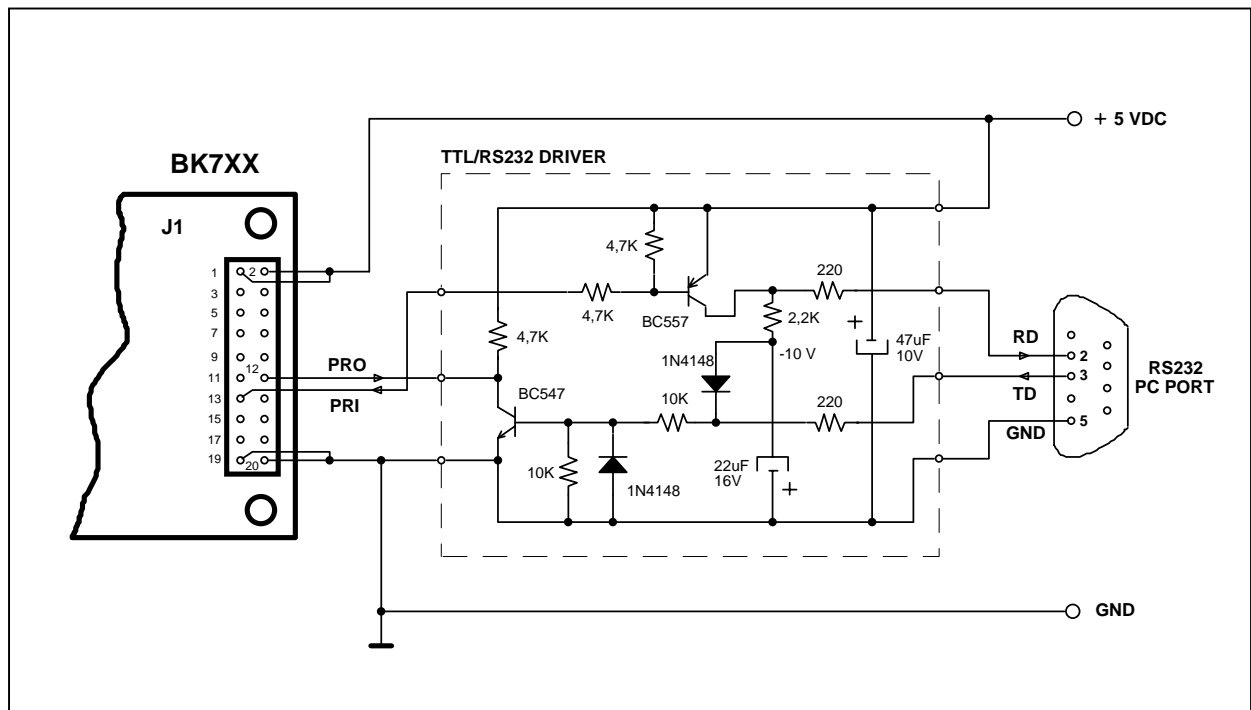

Fig . 10 PC/RADIO programming with TTL/RS232 driver.

Each channel can be individually programmed on new frequencies (and RF power level) : the new data will be retained into the radio memory (EEPROM).

At any time, if necessary, a “RESET” command reloads the memory with the “DEFAULT” channels.

PROGRAMMING COMMANDS AND PARAMETERS

[**CH**] WRITES IN “EEPROM” TX FREQUENCY, TX POWER LEVEL (HIGH, LOW) AND RX FREQUENCY.

FORMAT : CH (§ , &&&& , \$\$\$\$) [CR] [LF]

§ = CHANNEL NUMBER (HEX FORMAT, FROM 0 TO F)

& = 4 HEX DIGITS , “ NT” NUMBER.

\$ = 4 HEX DIGITS , “ RT” NUMBER.

[CR]= CARRIAGE RETURN (ASCII CODE 0D)

[LF]= LINE FEED (ASCII CODE 0A)

[**RESET**] GENERAL RESET WITH “EEPROM” RELOADED WITH “ DEFAULT” CHANNELS

FORMAT : RESET [[CR]] [LF]

[**#**] DATA REQUEST

FORMAT : # [CR] [LF]

AT RECEPTION OF “ # “ COMMAND , THE RADIO ANSWERS BACK THE ACTUAL PROGRAMMED DATA AND OPERATION MODE.

ASWER FORMAT : # α β § XXXX [CR] [LF]

α = RADIO STATUS (T = TRANSMISSION, R= RECEPTION)

β = RADIO MODE (V = VOICE, D = DATA)

§ = SELECTED CHANNEL (HEX FORMAT , 0 TO F)

X = 4 HEX DIGITS , “ NT” OR “ RT” NUMBER.

[CR]= CARRIAGE RETURN (ASCII CODE 0D)

[LF]= LINE FEED (ASCII CODE 0A)

NOTES :

- 1) Characters must be sent as written : capital letters, hex numbers, commas and round brackets.
- 2) A two seconds “Time-out” is active between character typing.
- 3) In case of error or “Time-out” the radio answer-back “ ? ” character.
- 4) The 16 channels are numbered 1-16 (see table 1). When programmed with “CH” command channels must be entered as Hexadecimal number from “0” to “F”.
- 5) [CR] and [LF] (if correctly configured into HyperTerminal program) are automatically sent by pressing “ENTER”.

NT and NR number calculation (BK 78x)

“NT” and “NR” are 16 bit binary numbers used to program the “PLL” N-divider in TX and in RX mode.

“NT” and “NR” are entered into the radio in Hexadecimal format. The “MSB” bit of “NT” is used as a flag to program the RF output power : 1 = HIGH POWER , 0 = LOW POWER.

“NT” is calculated dividing the required TX frequency (KHz) by 12.5 (12.5 KHz is the frequency programming step).

“NR” is calculated from the required RX frequency (KHz) subtracting 21400 (21400 KHz is the first conversion intermediate frequency) and then dividing by 12.5.

The calculated “NT” and “NR” are 17 bit long binary numbers.

The two “MSB” (n° 16,17) bit are not used in frequency programming : n° 17 bit can be eliminated, while n° 16 bit is used in “NT” number as the power flag.

A) “NT” calculation :

- 1) $NT = TX \text{ FREQ. (KHz)} / 12.5$
- 2) Write NT in binary format.
- 3) Eliminate the “MSB” of binary number.
- 4) Convert in Hexadecimal format.
- 5) For “HIGH POWER” the “MSB” bit of the first Hex number must be set to “1” .

B) “NR” calculation :

- 1) NR number : $NR = [RX \text{ FREQ. (KHz)} - 21400] / 12.5$
- 2) Repeat point 2 to 4 as above.

EXAMPLE :

A) TX FREQ. = 869.4125 MHz

nT NUMBER = 69553 = 10FB1 H =	10000 1111 1011 0001	
NT NUMBER (LOW POWER) =	0000 1111 1011 0001	= 0FB1 H
NT NUMBER (HIGH POWER) =	1000 1111 1011 0001	= 8FB1 H

B) RX FREQ. = 869.4125 MHz

nR NUMBER = 67841 = 10901 H =	10000 1001 0000 0001	
NR NUMBER (LOW POWER) =	0000 1001 0000 0001	= 0901 H

“CH” command format to program channel n° 2 on 869.4125 MHz (transmit and receive) , high power :

CH (1,8FB1,0901) [CR] [LF]

TABLE 2

BK78x DEFAULT CHANNELS					
CH. N°	CH. HEX	FREQ. MHz	POWER LEVEL	“ NT ”	“ NR “
1	0	868.2125	L	0F51	08A1
2	1	868.2375	L	0F53	08A3
3	2	868.2625	L	0F55	08A3
4	3	868.2825	L	0F57	08A7
5	4	868.8125	L	0F81	08D1
6	5	868.8375	L	0F83	08D3
7	6	868.8625	L	0F85	08D5
8	7	868.8875	L	0F87	08D7
9	8	869.2625	L	0FA5	08F5
10	9	869.2875	L	0FA7	08F7
11	A	869.4875	H	8FB7	0907
12	B	869.5125	H	8FB9	0909
13	C	869.5375	H	8FBB	090B
14	D	869.5625	H	8FBD	090D
15	E	869.5875	H	8FBF	090F
16	F	869.6125	H	8FC1	0911

“S” selector test and adjustment points

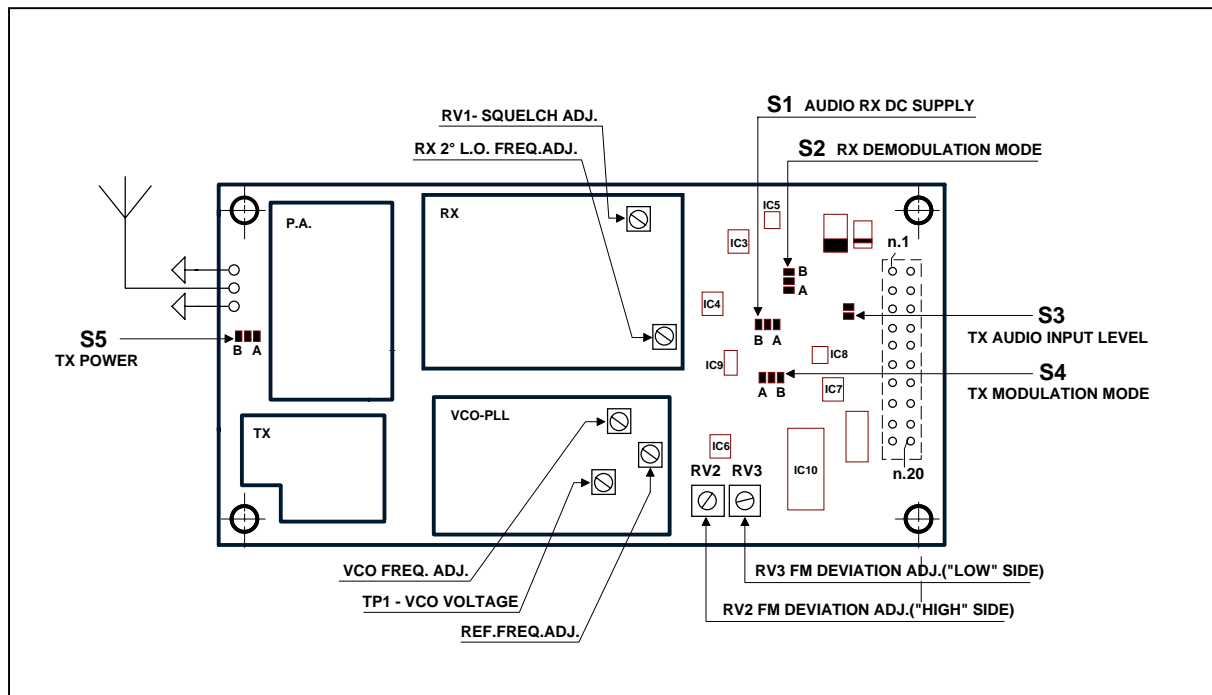

Fig. 11 - “S” selectors, test and adjustment points

1) “S” selectors (see also fig. 2 – block diagram)

S1 - Receiver 2° IF, lowpass filter, data slicer, etc. Power supply selection.

A = +5 Vdc supply

B = T-R switched supply

Note : T-R switching time is at a minimum (10 ms) with S1 in “A” position.

“B” position has the advantage to avoid any possible influence to TX modulation from RX fast switching circuits.

S2 - “PM” (- 6 dB/oct. de-emphasis) or “FM” (flat audio response) receiver demodulation system (only voice-analogue output) :

A = FM

B = PM

S3 - Transmitter audio input (ATX) level :

S3 open = 245 mV_{RMS} (-10 dBm , Z = 600 Ω)

S3 closed = 3mV_{RMS} (microphone level)

S4 - “PM” (6 dB/oct. emphasis) or “FM” (flat deviation) transmitter frequency modulation system (voice mode only) :

A = FM

B = PM

S5 - TX RF output power selection (BK77B5 – BK78B5 – BK79B5) :

S5 selector	Programmed output RF Power	
	H	L
A	500 mW	100 mW
B	100 mW	10 mW

Note : approximate values. Contact the factory for different power level .

<u>“S” selectors default position :</u>				
S1 = A	S2 = B	S3 Open	S4 = B	S5 = A

2) Test and adjustment points

- VCO TUNE** - VCO frequency adjustment.
Tension in TP1 (measured with an high impedance electronic voltmeter) must be approx. 1.2V in reception (0.6 V min.) and 2 V in transmission (2.4 V_{MAX}).
- FREQ.ADJ** - Reference frequency (X1 XTAL) adjustment.
The adjustment is best performed in transmission measuring carrier frequency with a frequency counter. The transceiver must be in “VOICE” mode.
- 2° L.O. FREQ.ADJ.** - Adjustment of the local oscillator (X1 XTAL) of the receiver ‘s second conversion.
- SQUELCH LEVEL** - Receiver squelch level adjustment, also responsible of the \overline{CD} (carrier detect) output activation.
The level can be adjusted from –130 dBm to approximately – 80 dBm.
- RV2 – RV3** - TX modulation deviation adjustment.
RV2 sets the “ HIGH SIDE” of the “Two-Points” modulation system from 600 Hz to 5 KHz.
RV3 sets the “LOW SIDE” from 600 Hz down to “DC”.

RV2 and RV3 adjustment is best performed in “DATA” mode with a 600 Hz square wave applied (TTL level) to TXD input.

While observing the demodulated signal from a modulation meter or test receiver.

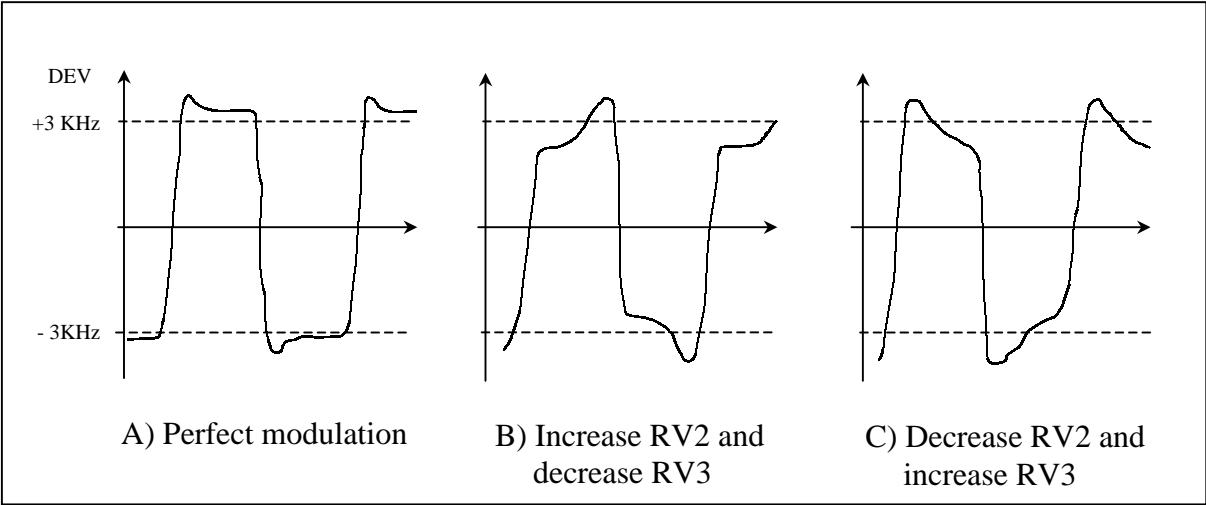

Fig. 12 Two points (VCO and Ref. Xtal) frequency modulation.

Antenna and mounting hints

The CEPT ERC/REC 70-03 recommends that short range devices (SRD) normally use either integral or dedicated antennas.

The most common and simplest antenna is the “Whip” groundplane. Other antenna styles together with practical considerations can be found on AN-B004 application note.

In fig. 13-A is described a suggest transceiver, antenna and control board layout : the metal enclosure is a good antenna groundplane and an efficient sreen between the radio and the antenna radiated field.

Although it is possible to mount the antenna directly on the radio P.C.B. (fig. 13-B) it must be considered the radio stability/performances can become impaired. The main reason is the presence of strong ground RF currents along the transceiver P.C.B. and the screening shields.

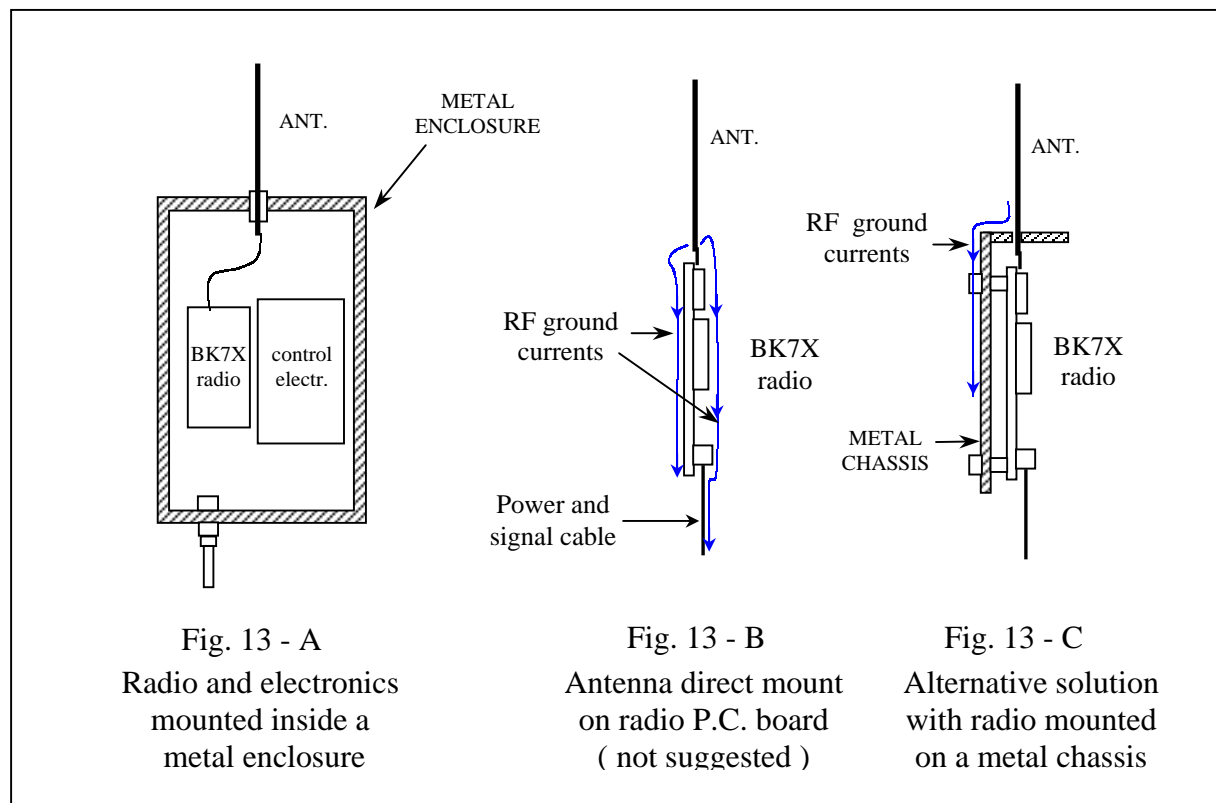

A good solution is depicted in fig. 13 – C where the transceiver is mounted , with four 2.5 MA metal screws and spacers, on a metal chassis wich acts as an efficient antenna ground and as a good RF currents return path.

Mounting the radio on a metal chassis is highly recommended to assure mechanical and electrical stability.

Especially in data transmission a stable FM deviation is of paramount importance to maintain High/Low side modulation balance.