

BT37	Sx	
SRD	RX	ISM 433.05 – 434.79 MHz

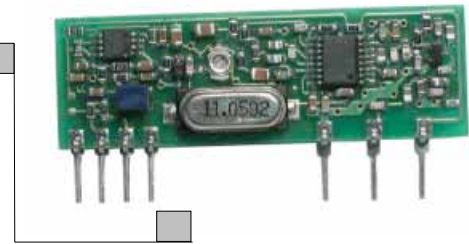

Table 1 – BT37S versions

BT37S3-F4	433.225 MHz	3 VDC	RF output power = +12 dBm (50Ω) Max ERP: a) 10 mW (+10 dBm). Band e – Duty-cycle <10%. b) 1 mW (+0 dBm). Band e1 – Duty-cycle <100%.
BT37S3-F18	433.925 MHz	3 VDC	
BT37S3-F23	434.175 MHz	3 VDC	
BT37S3-F4	433.225 MHz	5 VDC	RF output power = +13 dBm (50Ω) Max ERP: a) 10 mW (+10 dBm). Band e – Duty-cycle <10%. b) 1 mW (+0 dBm). Band e1 – Duty-cycle <100%.
BT37S3-F18	433.925 MHz	5 VDC	
BT37S3-F23	434.175 MHz	5 VDC	

- XTAL CONTROLLED ON 35 CHANNELS.
- FM MODULATION.
- HIGH POWER (+14 dB).
- FAST DATA RATE (19.2 KB).

DESCRIPTION :

The BT38S module is a complete transmitter module, "FM" or "FSK" modulated and crystal controlled on up to 35 different frequency channels in the 868 - 870 MHz band.

The carrier frequency is generated by a fixed division, low noise "PLL" integrated circuit (IC1). A Power Amplifier (P.A.) stage brings the RF output to the required power level.

"FSK" Digital (TXD Input) of "FM" Analog (AIN Input) modulation to the D1 Varicap Diode (X1 Crystal Reference Modulation).

A 5 poles Low Pass Filter attenuates the harmonic emissions under the EN 300-220 limits. The module needs a single 5VDC supply (BT38S5) or 3VDC supply (BR38S3).

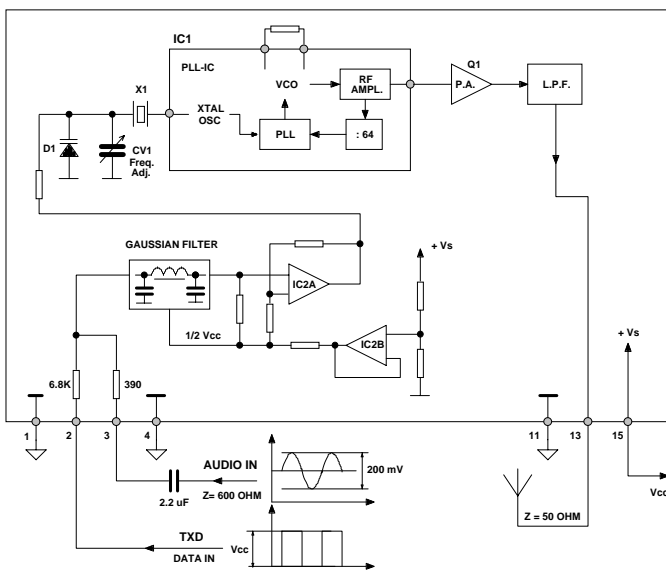

Fig.1 – BT37S – Block diagram.

Information about 50 KHz channel separation Band –Plan may be found in application note Anxx.

X1 Xtal specifications.

1. Holder: SX1 or HC45 (rear mount).
2. Mode: Fundamental – Parallel res.
3. Load cap: 15b pF.
4. Init. Precision: ±10 ppm.
5. Temp. stability: ±10 ppm.
6. Frequency: Fx = FTX / 64.

BT37S PERFORMANCE DATA

	Min	Typ	Max	Units	Notes
▪ FREQUENCY	433.05		434.79	MHz	(1)
▪ RF POWER BT37 S3 BT37 S5				mW	(2) (2)
▪ IMPEDANCE		50		Ω	
▪ FREQUENCY ACCURACY		± 3	± 5	KHz	(3)
▪ II HARMONIC		-50	-45	dBc	
▪ SPURIOUS EMISSION		-60	-55	dBc	
▪ DATA RATE			19.2	KB	
▪ POWER UP TIME			1	ms	
▪ SUPPLY VOLTAGE BT38 S3 BT38 S5	4.5 2.75	5 3	5.5 3.6	V V	
▪ SUPPLY CURRENT				mA	
▪ OPERATING TEMPERATURE	-20		+60	C°	

NOTE
 (1) CHANNEL SEPARATION = 50 KHz.
 (2) Max. legal Power = 10 mW ERP (SUB BAND F and G) – 5 mW ERP (SUB BAND K).
 (3) OVER OPERATING TEMPERATURE.

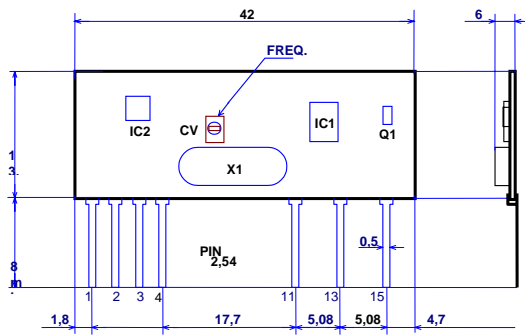

Fig.2 – BT37S – Physical dimensions.

PIN DESCRIPTION		
PIN1	GND	Ground
PIN2	TXD	Data Input
PIN3	AIN	Audio input
PIN4	GND	Ground
PIN11	GND	Rf ground
PIN13	ANT	Rf Output
PIN15	VCC	Dc supply

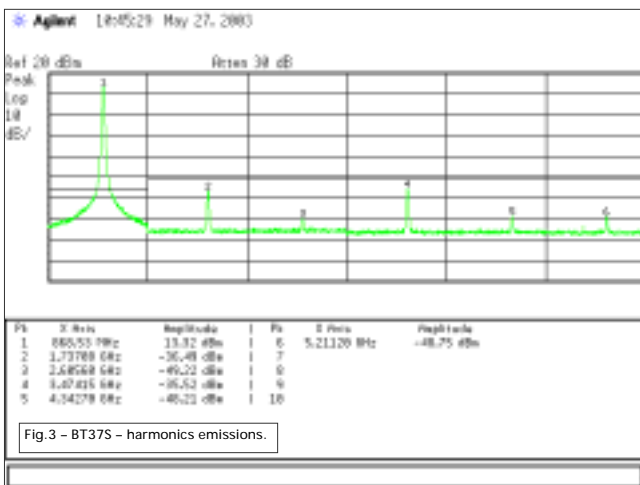

Fig.3 – BT37S – harmonics emissions.

DATA TRANSMISSION PROTOCOL:

The "Reference Frequency" modulation scheme allows for a flat response down to DC levels to avoid loss of balance in the transmitted signal even in presence of non symmetrical data patterns.

In data transmission (FSK modulation) nominal frequency deviation is obtained with a TXD signal level ranging from Zero to Vs (5V or V3).

Output RF carrier frequency, as adjusted by CV1, corresponds to F0 center channel frequency when TXD and AIN inputs are open state or when mean modulation signal level is VS/2.

